

**For the professional user**

# Operating Instructions

*Für den professionellen Anwender*

## *Betriebsanleitung*

**Class:** KA-ED  
**Klasse:**

**Model:**  
**Ausführung:** 22

**Dated:** 05.11.2025  
**Stand:**

## The sign of quality



**Y**ou find the Strobel trademark on every Strobel machine leaving our works. And with good reason. This symbol is a guarantee of the high quality of our products. Quality which creates trust – trust in our technology, our service and, not least of all, in our good name.

## *Im Zeichen der Qualität*

**S***ie finden die Strobel-Schutzmarke auf jeder Strobel-Maschine, die unser Werk verlässt. Und das aus gutem Grund. Denn dieses Zeichen garantiert Ihnen die hohe Qualität unserer Produkte. Qualität, die Vertrauen schafft – in unsere Technik, unseren Service und nicht zuletzt in unseren guten Namen.*

**S**trobel clients know that they can expect a particularly high standard of performance from our company and our machines. Now you have settled for one of our products. For us this is a source of encouragement and of obligation to Justify your trust.

If you wish to profit from the performance and efficiency of your Strobel machine as long as possible, exact handling and thorough care is necessary. For this reason we kindly request that you read the operating instructions closely.

It provides all the information you need for trouble free operation.

And if you do happen to need a spare part the enclosed spare parts list gives a complete overview. It is clearly classified according to components so that you can find the required part quickly and easily. In order to avoid errors we request you to quote machine class, machine number and part number completely on your spare part order.

We wish you lots of success in your work with your new Strobel machine.

# Garantiekarte/Warranty Sheet

**STROBEL**

Boschstraße 16  
D-82178 Puchheim  
Tel.: 089/80096-0  
Fax: 089/80096-190  
[info@strobel.biz](mailto:info@strobel.biz)

Maschinenklasse/Machine class: \_\_\_\_\_

Serien-Nr./Serial No: \_\_\_\_\_

Auftrags-Nr./Order Confirmation No: \_\_\_\_\_

Lieferdatum/Delivery Date: \_\_\_\_\_

Rechnungs-Nr./Invoice No: \_\_\_\_\_

Rechnungsdatum/Invoice Date: \_\_\_\_\_

Beanstandung/Complaint: \_\_\_\_\_

\_\_\_\_\_  
\_\_\_\_\_  
\_\_\_\_\_  
\_\_\_\_\_



\_\_\_\_\_  
Datum/Date

\_\_\_\_\_  
Unterschrift/Signature:

*Bitte nicht vom Kunden ausfüllen/To be filled out by Strobel:*

	Datum	Bemerkung
EXA:		
ETA:		
PROD:		
EXA:		
BH:		

# TABLE OF CONTENTS

1	General notes on safety .....	5
2	General .....	7
2.1	Operating instructions .....	7
2.2	Class identification, serial number and orientation of the machine.....	7
2.3	Intended use of the machine.....	7
2.4	Technical data of the machine.....	8
3	Installation and commissioning.....	10
3.1	Lubrication (Fig. 2) .....	11
3.2	Transit support.....	11
3.3	Direction of rotation of the machine.....	11
3.4	Motor drive by tooth-belts .....	12
3.4.1	Tension of the tooth-belt (Fig. 3) .....	12
3.4.2	Checking the tooth-belt for the carriage drive.....	13
3.4.3	Positions of the machine .....	14
3.5	Pneumatic connection .....	16
3.6	Power supply.....	16
3.7	Check light barriers .....	16
4	Notes on use and maintenance .....	17
4.1	Needles and threads .....	17
4.2	Inserting the needle (Fig. 7) .....	17
4.3	Thread monitor .....	18
4.4	Threading (Fig. 8a + b) .....	19
4.5	Operating element in the distribution box.....	19
4.5.1	Main switch S0 (Fig. 9) .....	19
4.5.2	Toggle switch S12 (Fig. 9).....	20
4.6	Operating elements in the switch box.....	20
4.6.1	START button S4  (Fig. 10) .....	20
4.6.2	STOP button S5  (Fig. 10) .....	21
4.6.3	Toggle switch S6 (Fig. 10).....	21
4.6.4	Light L2 (yellow) (Fig. 10) .....	21
4.6.5	Button “1” on the V810 operating control (Fig. 10).....	22
4.6.6	Button “2” on the V810 operating control (Fig. 10).....	22
4.6.7	Button “3” on the V810 operating control (Fig. 10).....	22
4.6.8	Button “4” on the V810 operating control (Fig. 10).....	22
4.7	Inserting the sewing material (Fig. 11 + Fig. 16b).....	23
4.8	Setting the stitch depth (Fig. 10 + Fig. 12a) .....	24
4.9	Digital stitch depth display (Fig. 10) .....	25
4.10	Setting the seam distance (Fig. 13).....	25
4.11	Setting the stitch length (Fig. 12b) .....	26

4.12	Finetuning the upper transport (Fig. 14) .....	27
4.13	Function sequence .....	28
4.13.1	Main switch S0 .....	28
4.13.2	Close clamping device, lapel part is inserted .....	28
4.13.3	Start of the automatic sewing process .....	29
4.13.4	Retraction of the carriage (only once after the start) .....	29
4.13.5	Sewing a blind stitch .....	29
4.13.6	Retraction of the carriage .....	29
4.13.7	End of the sewing program (S10 "light" and S8 "light") .....	30
4.14	+Machine maintenance (Fig. 16a) .....	31
5	Notes on repair and adjustment .....	32
5.1	The edge distance at stitch start and at the stitch end (Fig. 16).....	32

**Appendix**

**Strobel – Switchable functions (DC1500-AB221A)**

**Strobel – Parameter list (DC1500-AB221A)**

Subject to change without prior notice



**Fig. 1**

Klasse KA-ED (gez. rechts)

Class KA-ED (drawn right)

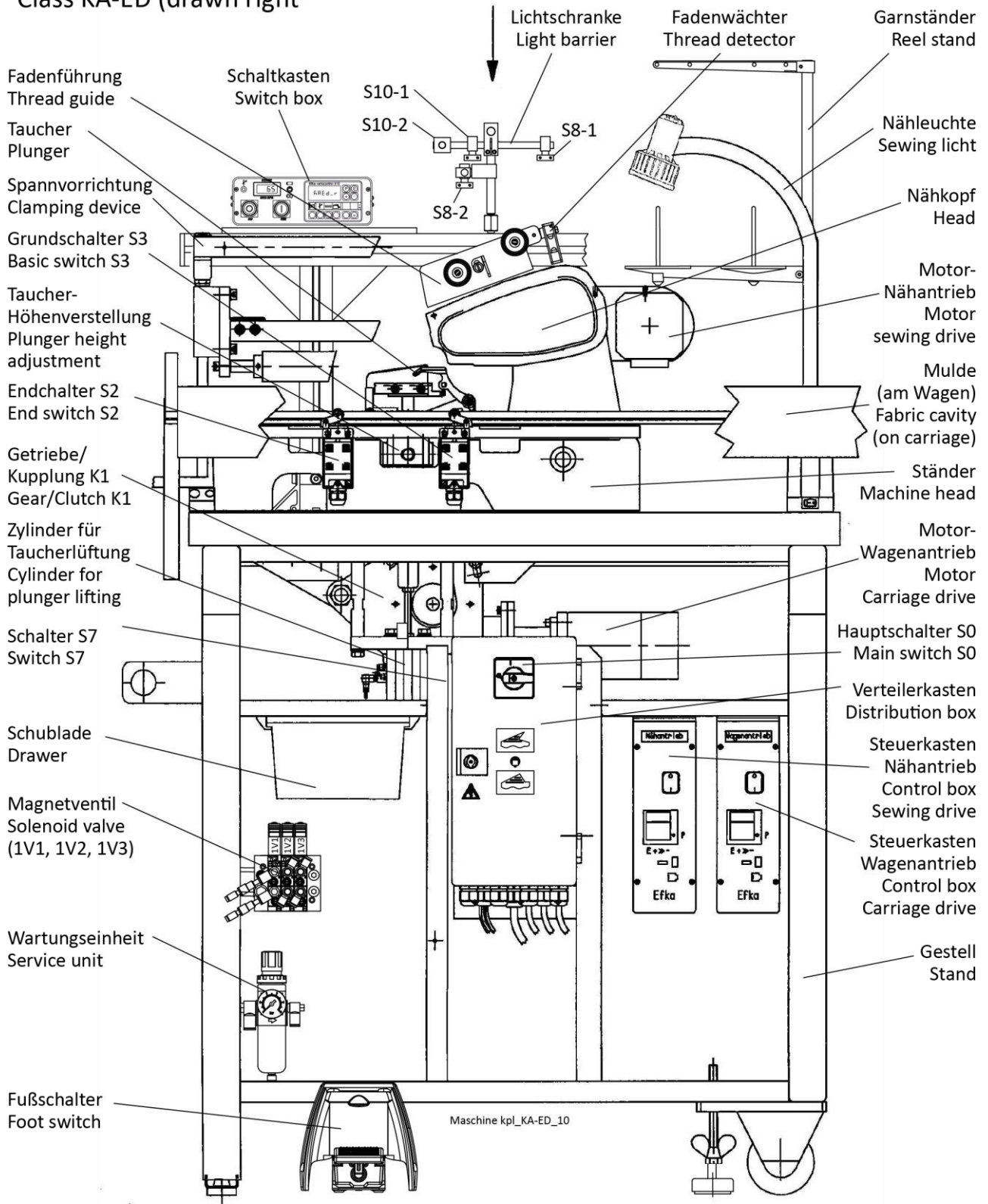

## 1 General notes on safety

Manuals and additional information can be found on the STROBEL website at:

**<http://www.strobel.biz>**

Every person in charge of setting up, operating, servicing and repairing the machine must first read and understand the operating instructions and particularly the safety instructions before starting up the machine.

**Failure to comply with the following safety instructions can lead to physical injuries or damage to the machine.**

1. The machine must only be operated by persons familiar with the relevant operating instructions and who have been instructed accordingly.
2. Before commissioning also read the notes on safety and the operating instructions of the sewing drive manufacturer.
3. Only use the machine in the intended manner and never without the provided guards. Always observe the pertinent safety regulations.
4. Switch off the main switch or pull the power plug for threading, changing the bobbin, exchanging sewing tools such as needle, hook, stitch plate, transport devices, trimming knife and cutting block, for cleaning and when leaving the workplace as well as for maintenance.
5. General maintenance tasks may be carried out only by properly trained persons in accordance with the operating instructions.
6. Repair work, retrofitting and maintenance may be carried out only by technicians or specially trained personnel.
7. When servicing or repairing pneumatic equipment, the machine must be disconnected from the pneumatic supply. Exceptions are only allowed for adjustment work and tests of functionality performed by specially trained technicians.
8. Only specially qualified technicians may work on the electrical equipment.
9. It is forbidden to work on electrically live components! Exemptions are covered by the EN50110 (DIN VDE0105) regulations.
10. Any retrofitting or alterations to the machine may only be performed under strict compliance with all pertinent safety regulations.
11. Only use our approved spare parts when servicing and/or repairing the machine.
12. It is forbidden to operate the sewing head until it is determined that the entire sewing unit complies with EU provisions.

13. It is essential that you observe and follow these instructions as well as the generally valid safety regulations.
14. Warning instructions given in the operating instructions that pertain to especially dangerous parts of the machine must be indicated at these positions using a safety symbol.



Warning instructions given in the operating instructions that pertain to special injury hazards for operating personnel or technicians must be indicated at these positions using a safety symbol.



## **2 General**

### **2.1 Operating instructions**

Any person involved in the installation, operation, maintenance and repair of the machine must have read and understood the operating instructions and in particular the safety instructions before starting the machine.

### **2.2 Class identification, serial number and orientation of the machine**

The operating side of the machine is the basis for orientation for descriptions referring to sides.

The class identification (type) is located on the right hand side of the machine stand; the serial and model number (after the dash) are stamped into the base plate's front surface on the back as well as on the type sign on the back side of the machine stand.

### **2.3 Intended use of the machine**

For automatic roll padding of right and left lapels, completely mirrored and not warped.

The Strobel roll padder consists of a left and a right machine. Both machines operate independently from each other.













The longest possible stitch length at the lapel roll line is 55 cm, the shortest stitch at the lapel tip is about 3 cm.

The shape of the lapel can be user-defined. The edges are scanned automatically by light barriers.

The edge distance at stitch start (10 mm – 25 mm) and at the stitch end (10 mm – 50 mm) can be freely set.

The distance between the seams can also be freely set up to about 16 mm.

## 2.4 Technical data of the machine

	Empfohlene Nennstichzahl / Recommended rated speed	2800 min-1
	Stichlänge / stitch length	6,5 mm
	Obertransport & differenzierbarer Wagentransport / top feed & differential carriage transport	
	starrer Drücker / fixed plunger	
	Stichplattenöffnung / needle plate opening	6,0 mm
	Stichtiefenanzeige / stitch depth display	digital display
	Nahtabstand / seam distance	4 - 16 mm
	Nadelsystem / needle system Nadelstärke / needle size	GROZ-BECKERT 4669 EEO 80/12
	Fadenspannung / thread tension Faden / thread	Auslieferungszustand / delivery condition 9 cN Polyester, endlos gewirnt / polyester continuous filament 200/2
	2 Nähköpfe / 2 sewing units	
	Fadenwächter / thread monitor	
	Laser Positionierung / laser positioning	optional
	Halogen Nählicht / Halogen sewing light	

<b>Technischer Auslieferungszustand / delivery condition:</b>	
Gesamtleistung / power consumption	2 x 1040 W
Stromanschluss / electricity	190 - 240 V / 50-60 Hz
Zahnriemenprofil / toothed belt profile	HTD 5M-9
Zahnriemenscheibe Maschine / toothed belt pulley/machine	Z = 38
Zahnriemen - Scheibe Wagen / tooth belt - wheel carriage	Z = 40 - HTD 5M-15-HP
kürzeste Naht / shortest seam	3 cm
max. Reverslänge / max. lapel length	63 cm
max. Nahtlänge / max. seam length	55 cm
Tagesleistung / daily output (8 h)	500 - 1050 Sakkos / pair of lapels
Stichart / stitch type	Einfaden-Kettenstich-Blindstich Typ 103 / single thread chain stitch type 103
Anschluss pneumatisch / pneumatic connection	5 - 6 bar
Luftverbrauch, Mittelwert / average air consumption	2 x 475 l / h
Gewicht ohne Verpackung / weight without packaging	2 x 158 kg
Arbeitsgeräusch / operating noise at 2800 min-1 nach DIN 45635-48-1 KL3	LpAm 77 dB(A)

### 3 Installation and commissioning

The S0 main switch is located on the distribution box below the tabletop (Fig. 1). The stop button S5  is located in the control box over the tabletop (Fig. 10).



#### **C A U T I O N ! Danger of injury!**

The machine's carriage run extends beyond the outer edge of the machine during operation. Make sure that this area is not accessible, because otherwise there is a **danger of injury**.

The machine may not be operated without protective panels (belt protection) for the upper part and for the motor (beneath the table top). Otherwise there is a **danger** of fingers being caught, bodily injuries and clothing being drawn in.



#### **A T T E N T I O N !**

Don't use as a handle!

Proceed as follows for installation: unpack and clean machine.

### 3.1 Lubrication (Fig. 2)

	<b>ATTENTION!</b>
The machine must be oiled before first start. The maintenance instructions according to the operating instructions must be followed!	

On the machine head all the points marked red. The lids (1) and (2) need to be screwed off for this.

**Fig. 2**

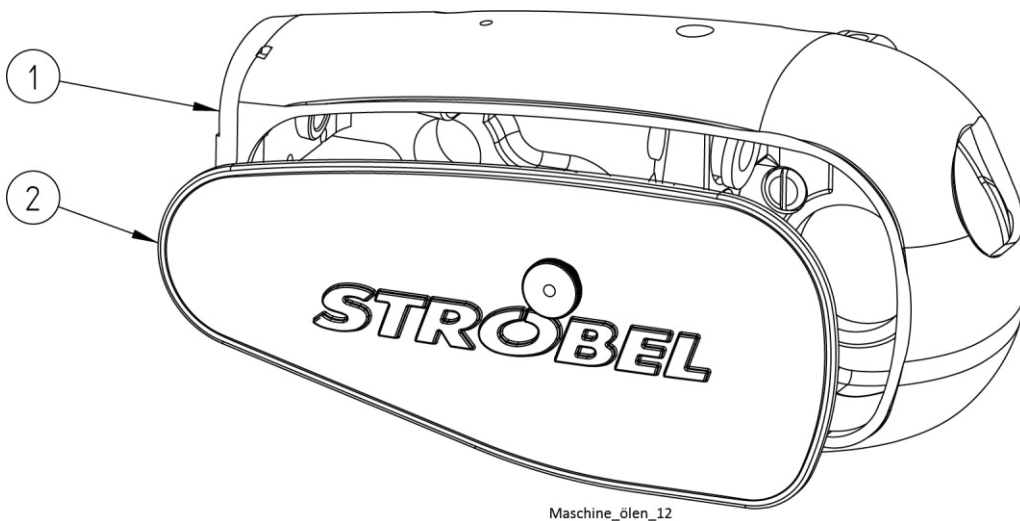

### 3.2 Transit support

Remove carriage lock. Unscrew an angle bracket each at the bottom side of the carriage.

### 3.3 Direction of rotation of the machine

#### **Right machine half:**

The correct rotation of the hand wheel is counter-clockwise (left run) when looking at it.

#### **Left machine half:**

The correct rotation of the hand wheel is clockwise (right run) when looking at it.  
Motor drive by tooth-belts

### 3.4 Motor drive by tooth-belts

#### 3.4.1 Tension of the tooth-belt (Fig. 3)



#### **CAUTION ! Danger of injury!**

Before testing the tooth-belt tension it is essential to switch off the machine by the main switch S0 and to disconnect the power plug.

The machine may not be operated without belt protection for the motor.

The tooth-belt should not be tensioned too tight. You should be able to compress it easily with your thumb by about 5 mm.

Too little or too great tooth-belt tension can be bad for the machine's positioning and thus impair the function sequence.

Tension the tooth-belt (Fig. 3):

- Loosen the upper and lower fastening screws (1), (2) on the machine upper part.
- Pull motor out a little and slightly tighten the lower fastening screw (2).
- Tension the tooth-belt by swivelling the motor.
- Tighten the upper and lower fastening screws (1), (2) again.

**Fig. 3**

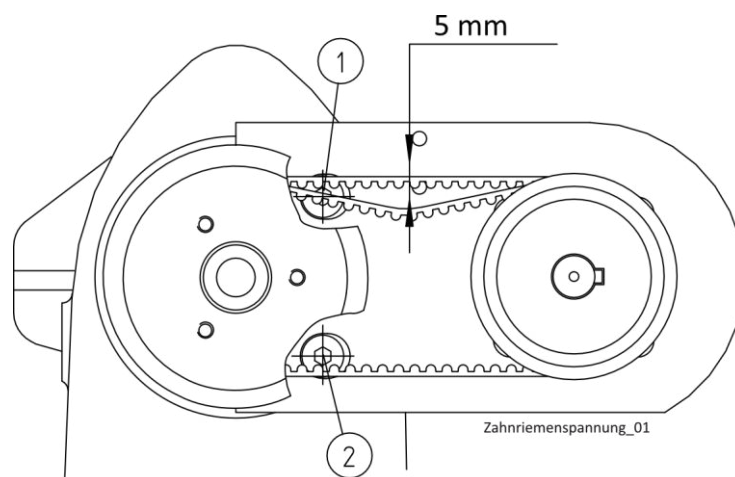

### 3.4.2 Checking the tooth-belt for the carriage drive



#### **CAUTION ! Danger of injury!**

To check the tooth-belt, switch off the machine electrically and pull out the power plug.

The machine may not be operated without front panels and back wall.

#### **Checking the tooth-belt tension (Fig. 4):**

- Switch off power switch S0 and pull the power plug.
- Unscrew front panel and rear wall from the frame.
- The tooth-belt (1) should not be tensioned too tight. You should be able to compress it easily with your thumb by about 5 mm. If the belt is too loose or too tight, the function sequence is impaired. If the belt is too tight, it will wear too quickly. In either case the machine will operate slower. The carriage may bend if the tooth-belt is too tight.

In case the belt tension is not OK, tension the belt properly.

- Loosen central fastening of the drive unit  
Hexagonal screw M16x80 (2)  
Hexagonal nut M16 (3)
- Loosen the fastening screw (4)
- The drive unit can now be swivelled around the central fastening. Tighten the belt and retighten the fastening screw. Retighten the central fastening.
- Screw front panel and rear wall to the frame.
- Plug in power plug and switch on main switch S0.

**Fig. 4**

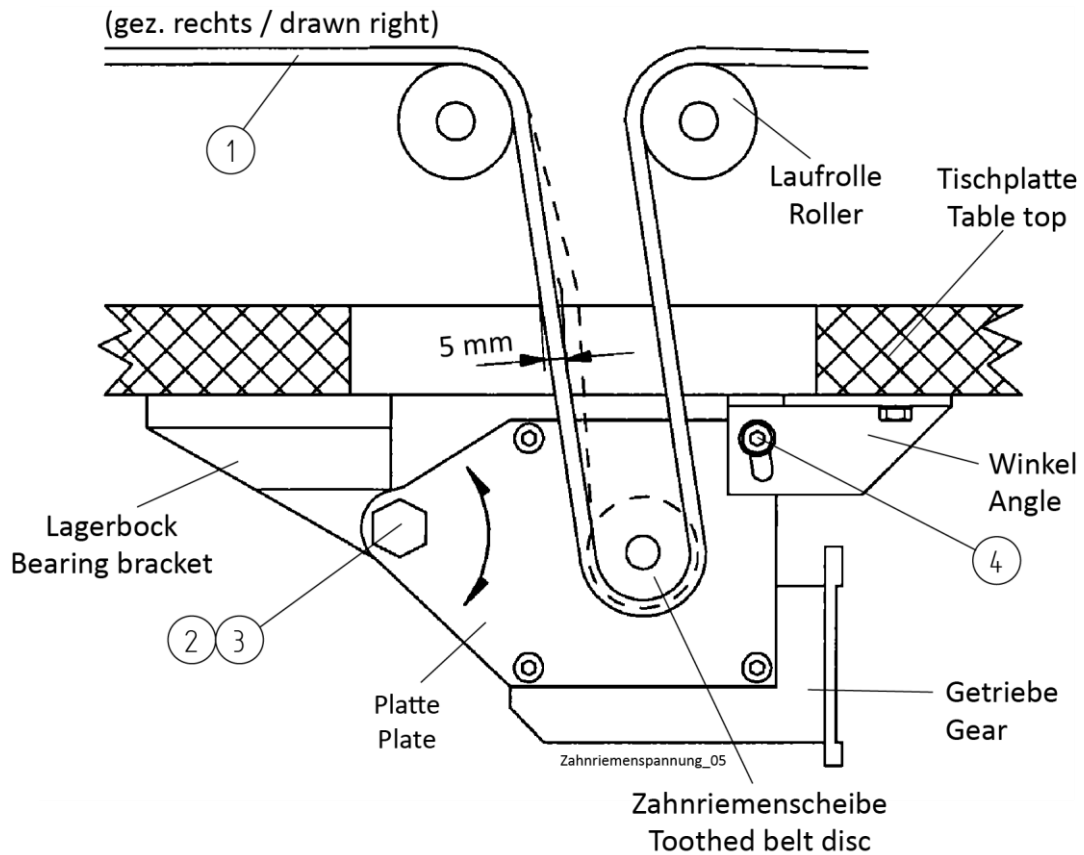

### 3.4.3 Positions of the machine



#### **CAUTION! Danger of injury!**

**Danger of injury** by clothing or hair being drawn in as well as danger of fingers being caught, and needle piercing!

When checking positions while the machine is turned on, keep fingers and hands away from moving parts.

The machine needs a needle position and a reference position.

#### **Reference position (Fig. 5):**

The reference position needs to be set so that the needle's point is aligned with the inner edge of the needle glide washers in the stitch-in direction.

**Fig. 5**

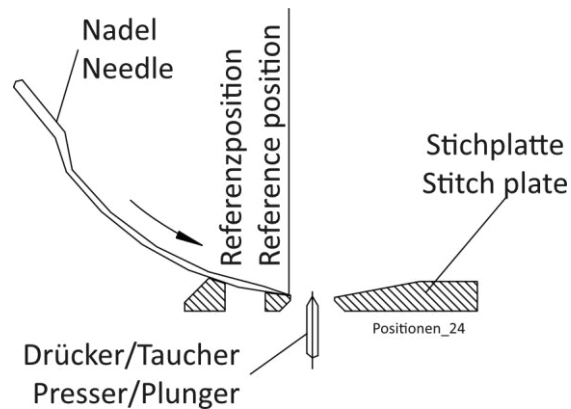

**Cutting position: (Fig. 6):**

After the looper has taken up the loop, the looper needs to be moved so far so that the thread of the loop on the needle side hangs on the cloth retainer and the other side slides in the groove of the cloth retainer. This way the loop half to be cut is placed on the cutter and is cut across the blade when the carriage retracts.

**Fig. 6**



This can be simulated by stopping the machine in the stitch with button 1 of the operating control V810 and activating the solenoid 1V1 by hand. Now the coupling has to be switched off by toggle switch S6 (Fig. 10) and the carriage pushed back by hand a little.

### 3.5 Pneumatic connection

Each half of the machine is separately connected pneumatically by an 8/6-PA hose to a connector plug. The maintenance unit is set to 5 to 6 bar operational pressure. Minimum operational pressure 5 bar.

### 3.6 Power supply



#### **CAUTION ! Danger of injury!**

Work on the electrical equipment may be done only by electricians or properly trained technicians. There exists the **danger** of fatal electrical shock.

The electrical connection is separate for each machine half.





#### **ATTENTION !**

Before connecting the machine electrically be sure that the local network voltage and the net frequency corresponds to the machine. Network voltage and network frequency can be found on the type sign on the back side of the machine stand.

If network voltage and frequency are not compatible, the electrical installation of the machine will be destroyed.

### 3.7 Check light barriers

- Clean mirror (1) for S8-1 and S10-1 and film (2) for S8-2 and S10-2 along the entire length and check for damages. (Fig. 16a)
- Push carriage manually to the middle.
- Switch on main switch S0.
- Press the START button S4  (carriage moves to basic position).
- Press START button S4  again (clamping device closes).
- Switch toggle switch S6 to "" position ("0" position) (carriage can be moved freely by hand) (Fig. 10).
- Keep an eye on the LED of the light barriers S8-1 and S10 and push the carriage through slowly by hand. The LED's should be lit without interruption along the entire length; otherwise re-adjust
- Test S10-2 with white inlay.

Machine is ready for sewing.

## 4 Notes on use and maintenance

### 4.1 Needles and threads

The sewing quality can be influenced to a considerable extent by choosing the most suitable needles and threads for the material to be sewn.

It is recommended to use checked GROZ-BECKERT needles system 4669 EEO only.

The machine is supplied with size 80/12 needles.

**NOTICE:** A perfect needle is of great importance for a good blindstitch. Damages of the needle point which often can be made visible under a magnifier only may deteriorate the sewing result. Replace your needle in time!

We recommend twisted polyester filament threads of size 180, 240, 300. Because of their high strength and ability to slide with a low thread volume they are to be preferred over a spun thread.



#### **G u a r a n t e e d   r e m a r k !**

This machine has been set and sewn off with **genuine GROZ-BECKERT needles**.

No guarantee can be granted if the settings are modified for using different needle types.

### 4.2 Inserting the needle (Fig. 7)



#### **C A U T I O N !   D a n g e r   o f   i n j u r y !**

Switch off the machine electrically with the main switch S0 before exchanging the needle.

Otherwise there is a **danger of injury** from crushing and needle punctures.

The curved shape of the needle dictates the position in the needle lever.

It just needs to be ensured that the needle shank is pushed in all the way in the groove of the needle lever and that the needle clamping plate (1) is held tight by the screw (2).

**Fig. 7**

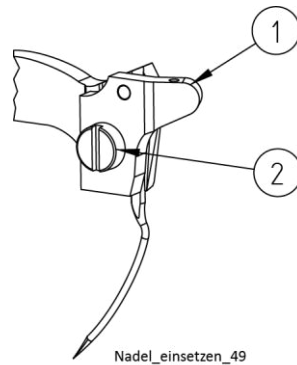

### 4.3 Thread monitor

During the sewing in automatic sewing mode the sewing thread is monitored for breakage. In case of a thread break the machine stops in the cutting position and the yellow light L2 (Fig. 10) starts blinking.

Thread controller consists of a sensor (Fig. 8a) that monitors the sewing thread.

**Fig. 8**

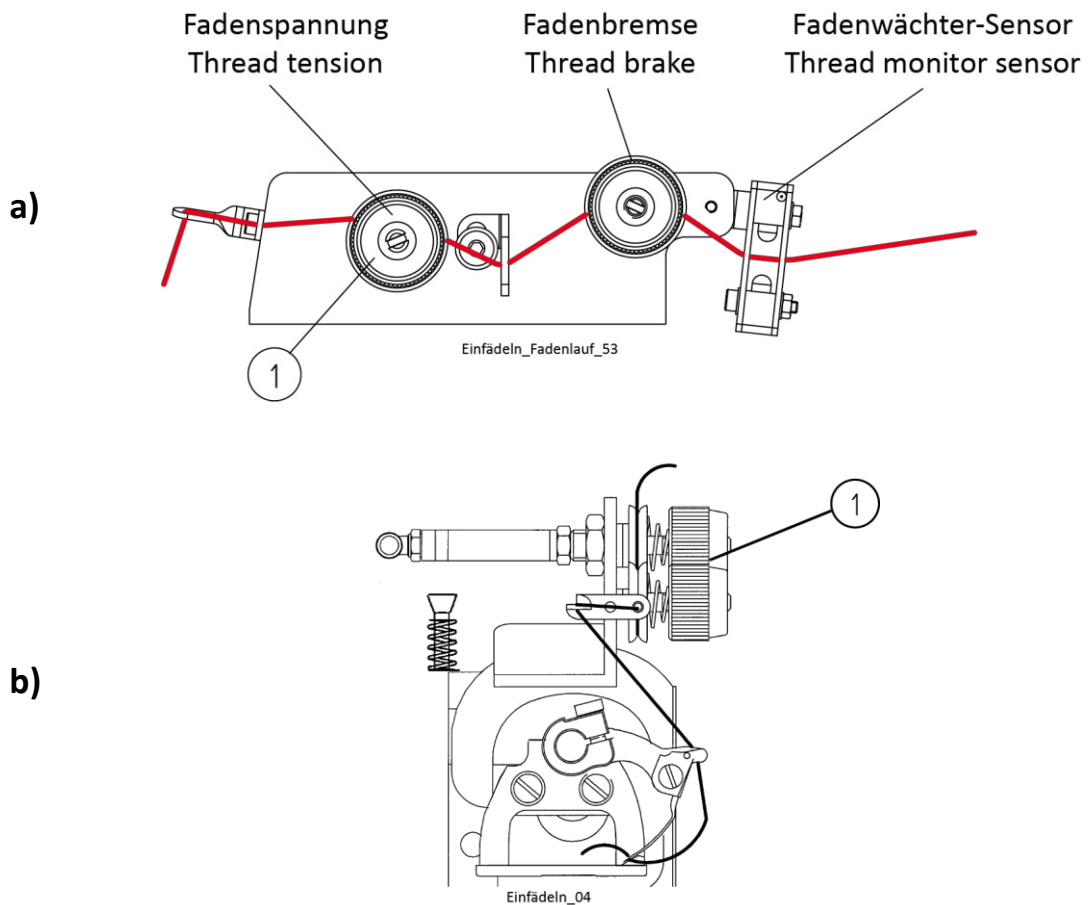

#### 4.4 Threading (Fig. 8a + b)



**CAUTION ! Danger of injury!**

Before threading switch off electrically with the S0 main switch in particular after the machine is stopped by the thread controller due to thread breakage.

Otherwise there is a **danger of injury** from crushing and needle punctures.

The thread has to be threaded in through the thread eyelets according to Fig. 8a + b. In the needle the thread is fed in from bottom to top into the eye of the needle.

#### 4.5 Operating element in the distribution box

**Fig. 9**

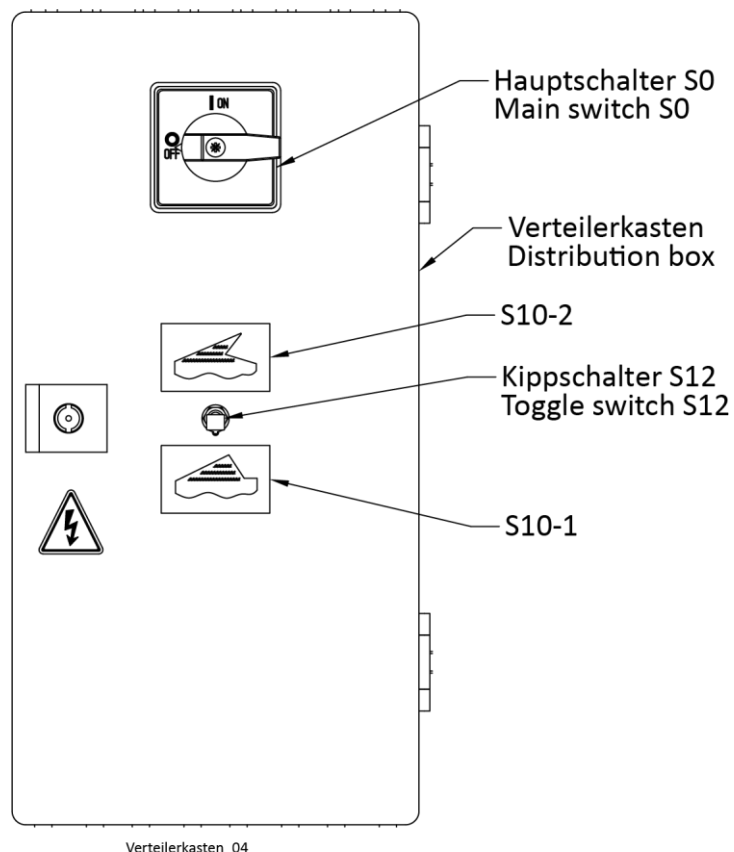

##### 4.5.1 Main switch S0 (Fig. 9)

The main switch S0 connects to the machine to the network voltage. If the carriage is not in its basic position, the yellow light L2 in the switch box KA-22 lights up (continuous light).

## 4.5.2 Toggle switch S12 (Fig. 9)

Use the toggle switch S12 to switch between the processings S10-1 and S10-2.

## 4.6 Operating elements in the switch box

**Fig. 10**

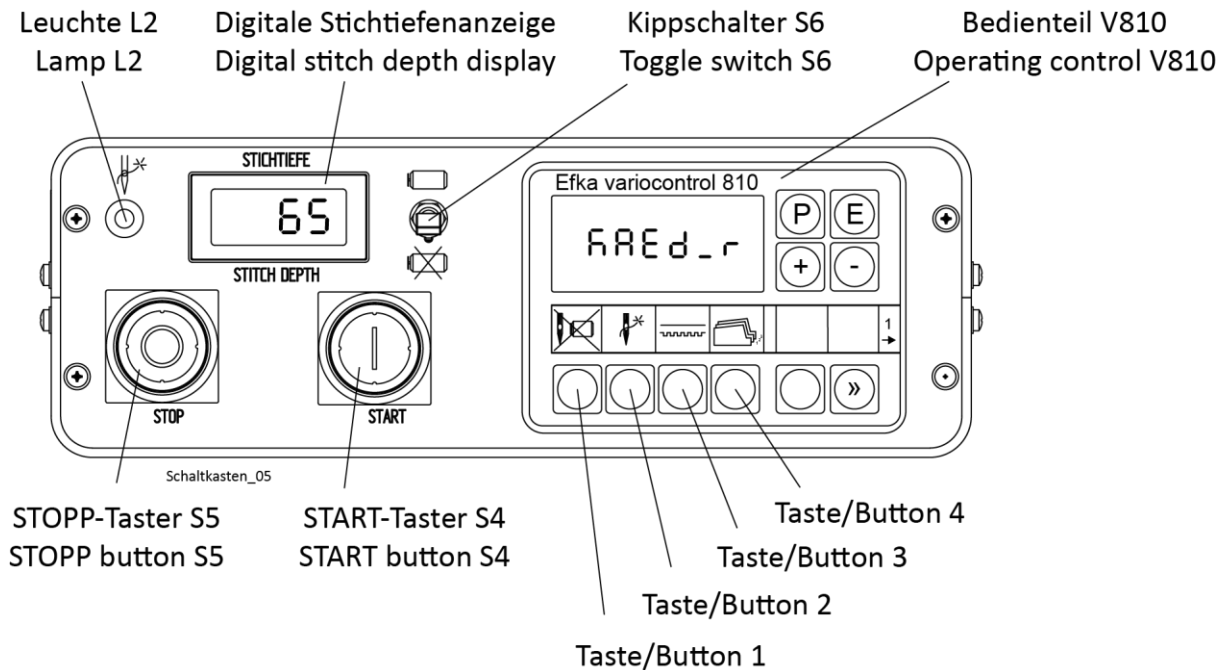

### 4.6.1 START button S4 (Fig. 10)



The START button S4 has several functions

- Retraction of the carriage into basic position.**  
If the carriage is not in its basic position when the main switch S0 is switched on, i.e. the yellow light L2 is lit, then the carriage can be driven to its basic position by pressing the START button S4.
- Closing the clamping device**  
When the carriage is in basic position and a lapel is inserted, the clamping device can be closed by pressing the START button S4.
- Starting the automatic sewing process**  
when the clamping device is closed, the automatic sewing mode can be started by pressing the START button S4.
- Retraction of the carriage into basic position after stop**  
If the machine is stopped by pressing the STOP button S5, the automatic sewing mode is interrupted. Afterwards the carriage can be retracted to the basic position by pressing the START button S4.



## 4.6.2 STOP button S5 (Fig. 10)



The STOP button S5  has two functions.

### 1. **Open clamping device**

If the clamping device was closed by pressing the START button S4 , it can be opened again by pressing the STOP button S5 .

### 2. **Switching off the automatic sewing process**

By pressing the STOP button S5  the machine stops immediately in the current position and the automatic sewing mode is interrupted. If the START button S4  is pressed afterwards, the carriage retracts to its basic position and the clamping device opens.

Each time the STOP button S5 button  is pressed the START button S4  is generally blocked for the time "t1".

## 4.6.3 Toggle switch S6 (Fig. 10)

The coupling K1 can be switched off by toggle switch S6. This allows the carriage to be moved freely when the main switch S0 is switched on. This is necessary for testing the light barriers.

Toggle switch S6 is switched to "" position ("0" position) in basic position:

- Coupling K1 is switched off.

Toggle switch S6 is switched to "" position ("0" position) in automatic sewing mode:

- The automatic sewing mode is interrupted, the machine stops in the current position and coupling K1 is switched off.

As long as the toggle switch S6 remains in the "" position ("0" position), "-Stop-" is displayed at the V810 operating control and all other operating elements of the machine (excepting main switch S0) are blocked.

Once the toggle switch S6 is returned to position "" (position "1"), operating the machine can be continued as usual.

## 4.6.4 Light L2 (yellow) (Fig. 10)

Various warning situations are indicated by light L2:

1. Continuous light - Carriage is not in basic position
2. Blinking - Thread has broken

#### **4.6.5 Button “1” on the V810 operating control (Fig. 10)**

Button 1 can be used to interrupt the actual “sewing” without ending the automatic sewing mode.

After switching off the function the actual sewing mode can be continued again by pressing the START button S4  (on the switch box).

#### **4.6.6 Button “2” on the V810 operating control (Fig. 10)**

Button 2 can be used to switch the thread controller on and off.

During the sewing in automatic sewing mode the sewing thread is monitored for breakage. In case of a thread break the machine stops in position 2 and the yellow light L2 starts blinking.

#### **4.6.7 Button “3” on the V810 operating control (Fig. 10)**

Button 3 can be used to set the ratio of the carriage transport to the upper transport (differential transport).

For the setting:

- 100 → carriage transport equals upper transport (synchronous)
- 101-500 → carriage transport is less than upper transport
- 000-099 → carriage transport is greater than upper transport

#### **4.6.8 Button “4” on the V810 operating control (Fig. 10)**

Button 4 can be used to display or delete the counter status of the part counter.

Display the counter: Press button 4

Delete the counter: Keep button 4 pressed for about 5 seconds when the counter is displayed.

## 4.7 Inserting the sewing material (Fig. 11 + Fig. 16b)

**CAUTION ! Danger of injury!**



The operator should take sufficient care when sewing and keep an eye on the sewing area. Otherwise there is a **danger of injury** from crushing and needle punctures.

Before closing the pneumatic clamping device by pressing the START button S4  both hands need to be withdrawn from the clamping area.

The part to be padded should be inserted in such a way that the lower part of the lapel lies towards the stitch plate; the stitches run from bottom to top on the lapel and from the front fold line towards the lapel tip (Fig. 11).

The first stitch comes in at about the point that lies along the reflective foil edge during inserting.

There is a red marking on the rear Differential feed. This mark identifies the point at which the machine starts with sewing at the earliest (Fig. 16b). The red marking on the bar after that marks the end of the sewing area.

**Fig. 11**

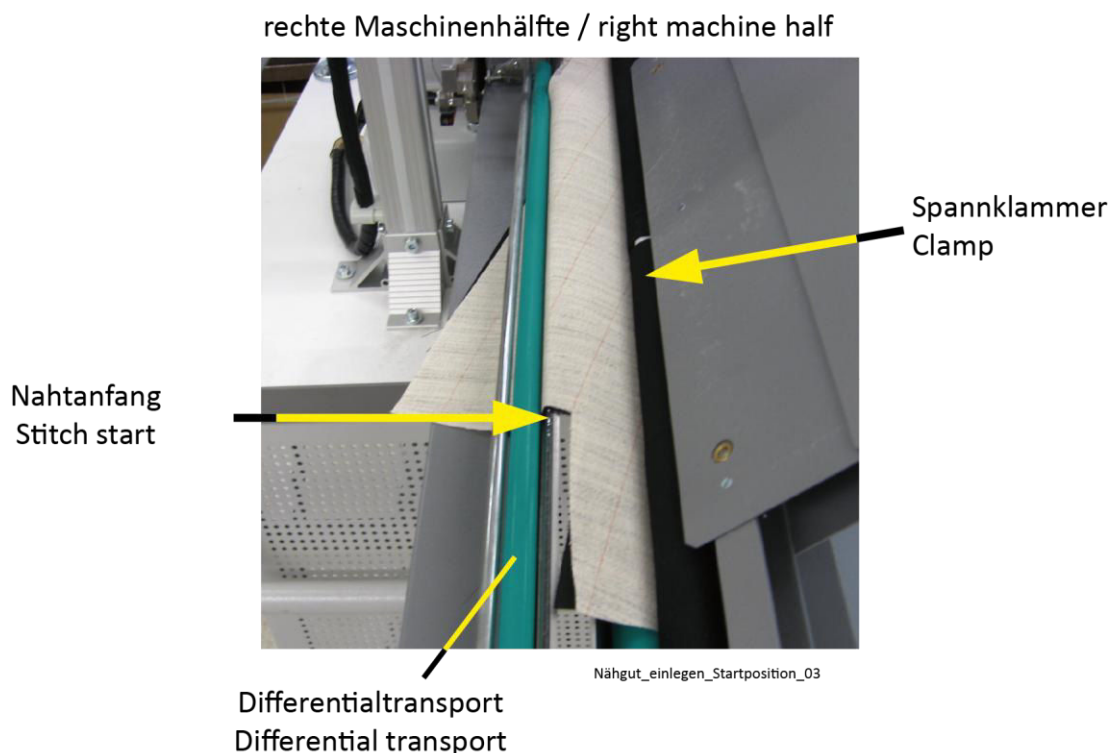

## 4.8 Setting the stitch depth (Fig. 10 + Fig. 12a)

The stitch depth can be set very exactly by a control knob in the front beneath the cavity. It is indicated optically by a three-digit display (Fig. 10).

**Fig. 12**

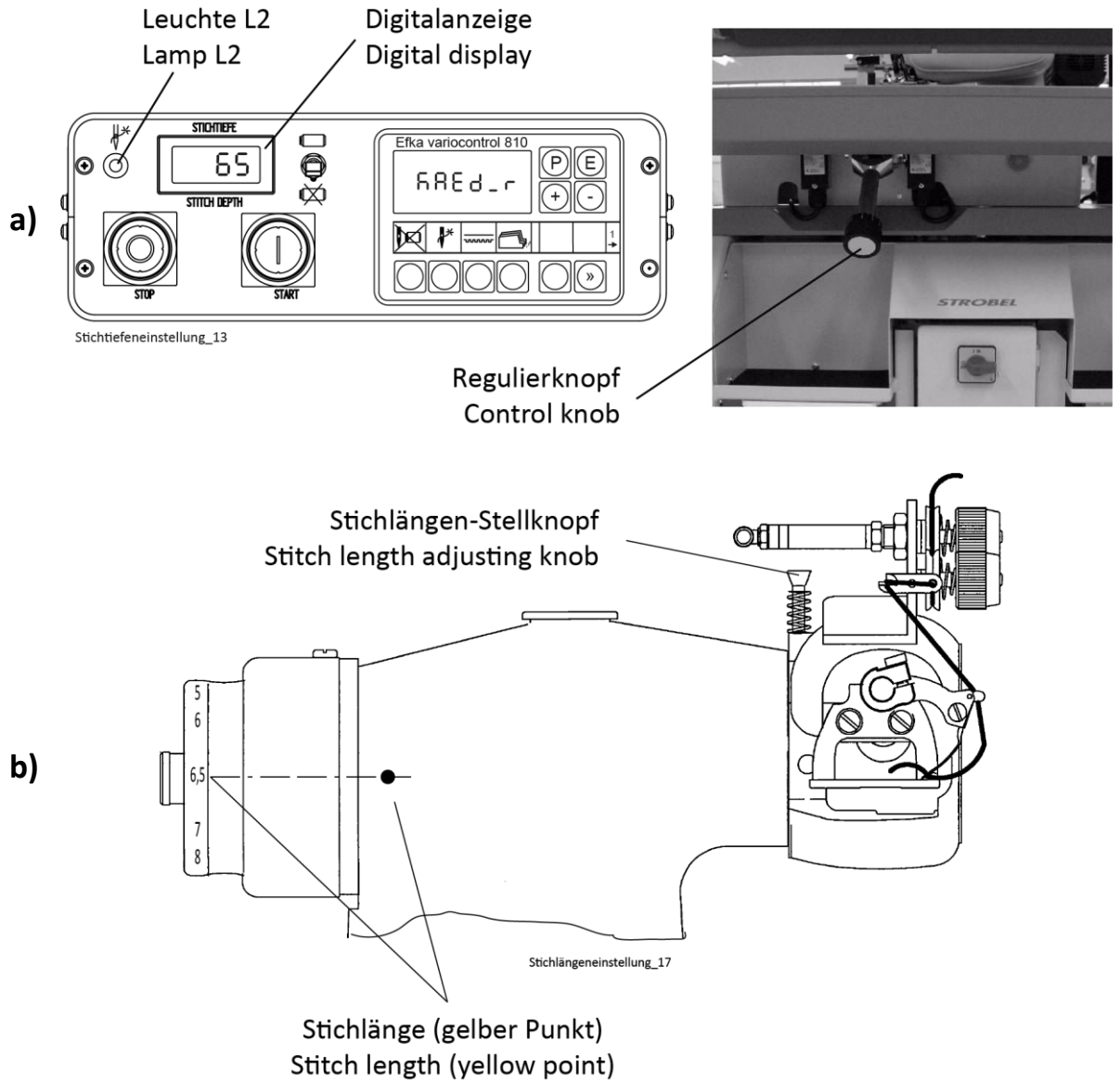

## 4.9 Digital stitch depth display (Fig. 10)

The digital stitch depth display permits a very precise height setting of the plunger. Changing a numerical value of the LC display corresponds to a height adjustment in the plunger of 5/1000 mm. A complete revolution on the regulating knob results in a change of the numerical value of exactly "100". This way the complete revolutions can be read on the left position of the LC display and on the middle and right position the percentile of a complete rotation can be read.

The basic rule is:

small numerical value = thin material  
greater numerical value = thicker material

## 4.10 Setting the seam distance (Fig. 13)

The distance between the stitches can be freely set up to about 16 mm. The adjustment is made on the front side of the carriage by the knurled nut (1).

**Fig. 13**

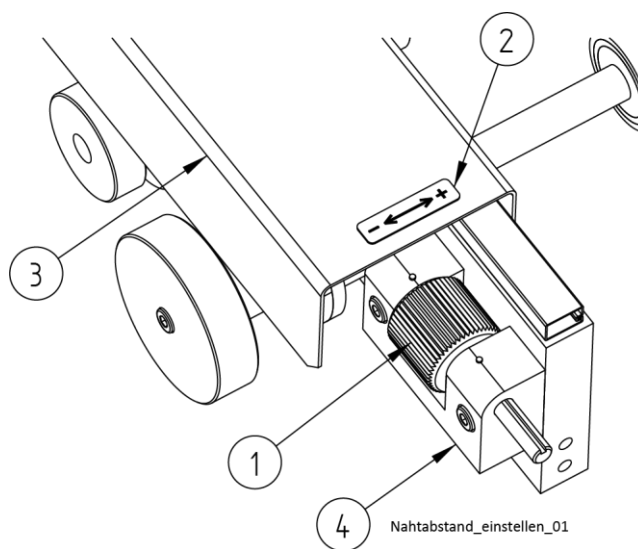

## 4.11 Setting the stitch length (Fig. 12b)

The stitch length on the roll padder is 6.5 mm constant.

The stitch length setting on the machine head can be used to even out transport differences when sewing material thicknesses are extreme.

### **As a rule:**

- |                                 |   |                        |
|---------------------------------|---|------------------------|
| thin to medium sewing material  | : | stitch length 6 to 6.5 |
| medium to thick sewing material | : | stitch length 6.5 to 7 |

### **Setting:**

- Switch off main switch S0.
- Press stitch length setting button down and turn handwheel in the machine's rotation direction (Fig. 12b) until the setting knob engages.
- Turn handwheel against the direction of rotation until the desired stitch length value on the handwheel agrees with the yellow mark on the machine stand.
- Release the stitch length setting knob again.

**IMPORTANT:** The installed return spring has to push the setting knob all the way back out; the handwheel needs to be freely turnable in the running direction.

## 4.12 Finetuning the upper transport (Fig. 14)

**Fig. 14**

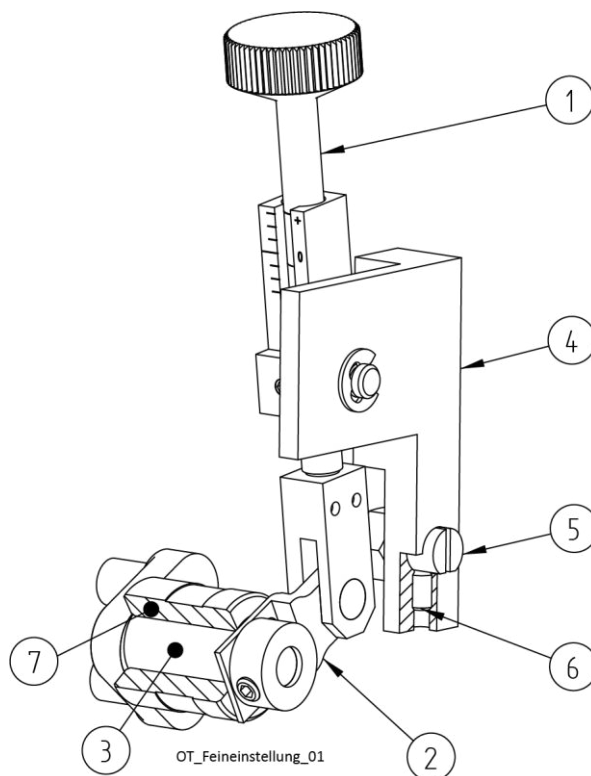

The feed dog is adjusted to its height by a threaded bar (1) with a lever (2) and an eccentric bushing (3).

The transport movement remains, through turning of the threaded bar (1) the feed dog can be adjusted to its height in order to eliminate warping of the sewing material.

It is important that this adjustment goes easily. Since the aluminium plate (4) is secured by only the bolt (5) with screw (6) and can be twisted somewhat, ensure that none of the movable parts get jogged or caught.

### **Setting procedure:**

1. Set stitch length at head to 8 mm.
2. Insert large eccentric bushing (7) with eccentric bore hole to the rear in the head. (Fig. 14)
3. Mount lever mechanism with eccentric brass bushing with bore holes towards the front.
4. Set the feed dog to such a height that the transport supports jam when the needle's point is on the right edge of the needle glide washer.
5. Set stitch length at head to 6.5 mm.

This setting is a bit difficult, because the feed dog can be shifted in all directions because of the large bore hole.

## 4.13 Function sequence

2 operation options can be selected using the parameter F-602.

- Option 1 (standard): Using the START (S4) and STOP (S5) buttons.
- Option 2 (foot switch): Using the foot switch (S13), START (S4) and STOP (S5) buttons.

F-602	0	=	Option 1 / standard
F-602	1	=	Option 2 / foot switch

### 4.13.1 Main switch S0

- Once the machine has been switched on with the S0 main switch and the control box has started up, the START button S4  can be pressed. With that, the carriage drives back into the home position. The plunger is lifted simultaneously (1V1 on). Once the home position has been reached (S3 opens contact), the yellow light L2 goes out and the plunger goes up again (1V1 off).
- If the carriage is already in its basic position after power on, the start commences as described under point "4.13.2 Close clamping device, lapel part is inserted".

### 4.13.2 Close clamping device, lapel part is inserted

- **Option 1 / standard**
  - By pressing the START button S4 , the clamping device and the rear differential transport are closed by the switching on of the solenoid valves 1V2 and 1V3.
  - The position of the clamping device is monitored by the light barrier S8-1.
  - Sequence continues at point „4.13.3 Start of the automatic sewing process“.
- **Option 2 / foot switch**
  - When foot switch S13 is pressed the first time, the differential feed (1V3) is closed.
  - When foot switch S13 is pressed the second time, the clamping device (1V2) is closed.
  - There needs to be a safety time of one second between the first and the second pressing. If the foot switch is pressed for the second time too early, the error message "E4" appears.
  - Sequence continues at point „4.13.3 Start of the automatic sewing process“.

### **4.13.3 Start of the automatic sewing process**

The automatic sewing mode can be started by pressing the START button S4  again. Once start is enable by the S8-1 light barrier (“light”, high signal), the plunger is lifted and the first side transport is run when the 1V1 solenoid switches on. The material is now ready for the first stitch. The thread brake is closed. The carriage is now driven in. Once the lapel edge has been reached – identification by light barrier S8 (“dark”, low signal) – the carriage is stopped after completing the reverse stitches “Stc1”. Sequence continues at point “4.13.4 Retraction of the carriage (only once after the start)”.

### **4.13.4 Retraction of the carriage (only once after the start)**

The carriage retracts until light barrier S8 detects “light” and stops then. When the 1V1 solenoid switches off, the plunger is closed and the thread brake opened. Sequence continues at point “4.13.5 Retraction of the carriage”.

### **4.13.5 Sewing a blind stitch**

The machine is sewing; the sewing material is transported by the carriage. The stitch ends when the light barrier S10-1/S10-2 changes from “dark” to “light” because of the sewing material. Light barrier S8 is at “dark” there. Seam end = S10-1/S10-2 “light” and S8 “dark”. The sewing is stopped. Once in cutting position, the plunger is lifted, a side transport runs and the thread brake closed when the 1V1 solenoid switches on. Sequence continues at point “4.13.6 Retraction of the carriage”.

### **4.13.6 Retraction of the carriage**

The carriage retracts until light barrier S8 detects “light” and stops then. The thread is cut at the start of retraction. Retraction end = S10-2 “dark” and S8 “light” When the 1V1 solenoid switches off, the plunger is closed and the thread brake opened. Sequence continues at point “4.13.5 Sewing a blind stitch”.

#### **4.13.7 End of the sewing program (S10 “light” and S8 “light”)**

The sequence described under point “4.13.5 Sewing a blind stitch” and “4.13.6 Retraction of the carriage” is repeated until the light barriers S8-1 and S10-1 detect “light” at the same time.

Sewing program end = S10 = “light” S8 “light”

Once the needle is positioned, the plunger is lifted, a **side transport** runs and the thread brake closed when the 1V1 solenoid switches on.

The carriage retracts until basic switch S3 is pressed and stops then.

Beginning with the retraction the delay time “t2” (parameter F-751) starts running.

After “t2” has expired the clamping device and the rear Differential feed are opened (1V2 and 1V3 off).

When the 1V1 solenoid switches off, the plunger is closed and the thread brake opened.

The renewed start of the sewing program is done as described under point “4.13.2 Close clamping device, lapel part is inserted”.

#### 4.14 Machine maintenance (Fig. 16a)



#### **CAUTION ! Danger of injury!**

Switch off the machine's electric power. Otherwise there is a **danger of injury** from crushing and needle punctures.



#### **ATTENTION !**

The machine must be oiled before first start. The maintenance instructions according to the operating instructions must be followed!

- Regular cleaning and lubricating of the machine is prerequisite for fault-free operation, smooth running, and long service life. For non-stop operation the machine head parts need to be oiled daily. The head cover has to be removed for this. The lubrication points are marked in red.
- The mirror (1) and the reflective foil (2) need to be cleaned along the entire length several times a day and be checked for damages.
- The reflection surfaces of the light barriers must be cleaned several times a day.
- The light barriers (3) on the light ray emitting side also need to be cleaned several times a day.
- Once every half year the tooth-belt for the carriage drive needs to be checked and retightened if necessary.  
(See point "3.4.2 Checking the tooth-belt for the carriage drive")
- Please lubricate the carriage guides (4X) ((4) Fig. 13) with enclosed special oil picture 1 (in set (1) Fig. 15) every two months.
- Plunger do not need any maintenance.

**Fig. 15**

Abbildung / Picture 1

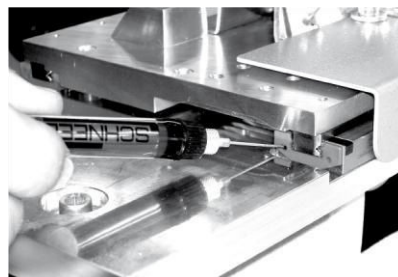
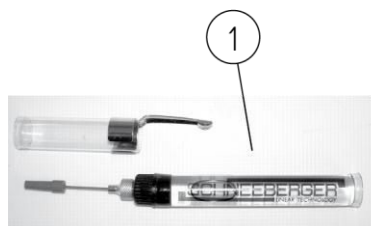

Maschine\_ölen\_14

## 5 Notes on repair and adjustment



### **CAUTION ! Danger of injury!**

Before maintenance and repair read the safety instructions and the operating instructions. If they are ignored, there may be serious bodily injury.

### 5.1 The edge distance at stitch start and at the stitch end (Fig. 16)

The setting range at the stitch start is 10 mm to 25 mm and at the stitch end 10 mm to 50 mm.

Light barrier S8-1 sets the distance at the stitch start (Fig. 16b).

If the light barrier is set closer to the needle, the distance to the edge is reduced and vice-versa.

If the light barrier is moved to the side, then make sure the position to the mirror/reflex foil is optimal.

The light barrier S8-2 is functionally switched parallel to the light barrier S8-1. Light barrier S8-2 determines the point at which sewing can begin at the earliest on the lapel under side. This position is marked by a red marking on the shaft in the back (1) (Differential feed) (Fig. 16b).

In case the mechanical setting range (edge distance) at the stitch start or stitch end is not enough, then this can be extended by changing the parameters in the programming mode.

With S10-1, the stitch end is set at standard lapel (Fig. 16b); with S10-2, the stitch end is set at peaked lapel (Fig. 16c).

**Fig. 16**

**a)**  
**Light barriers for right machine**  
 (Left machine is mirrored)

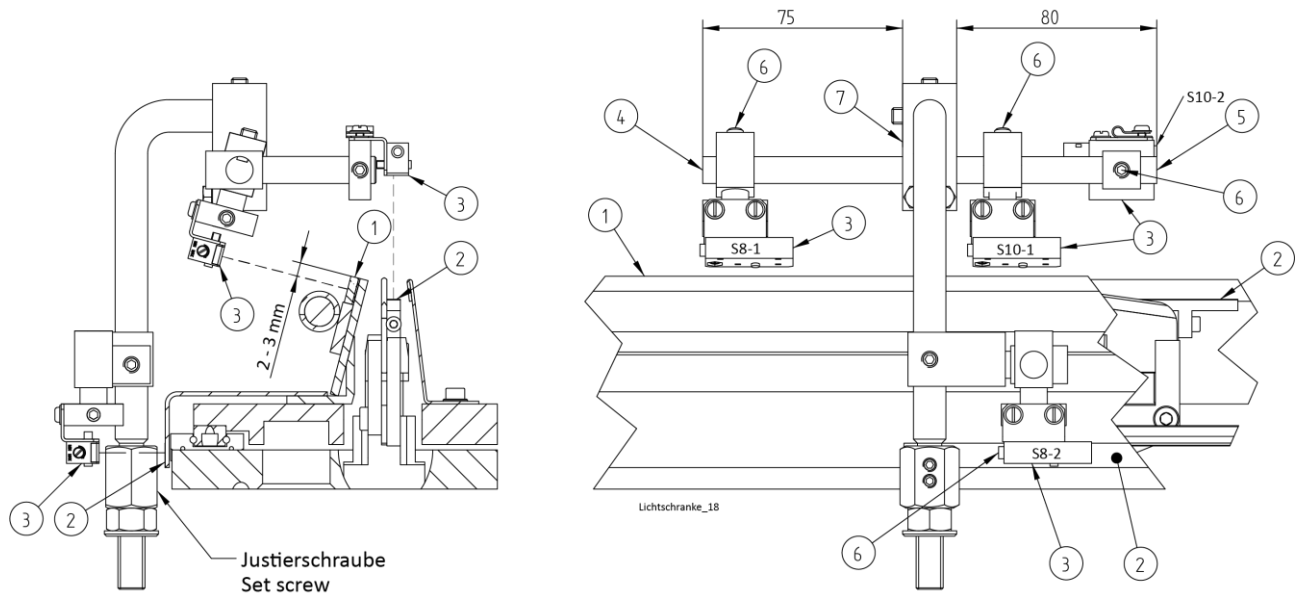

**b)**

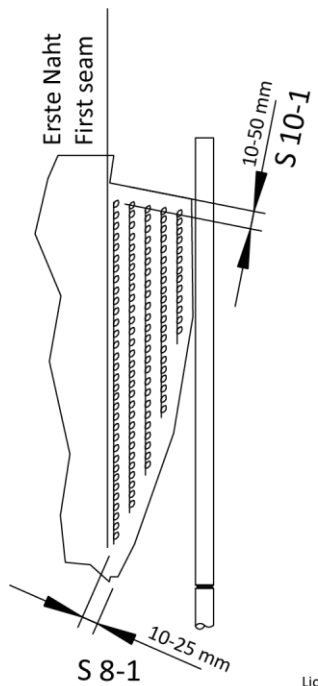

**c)**

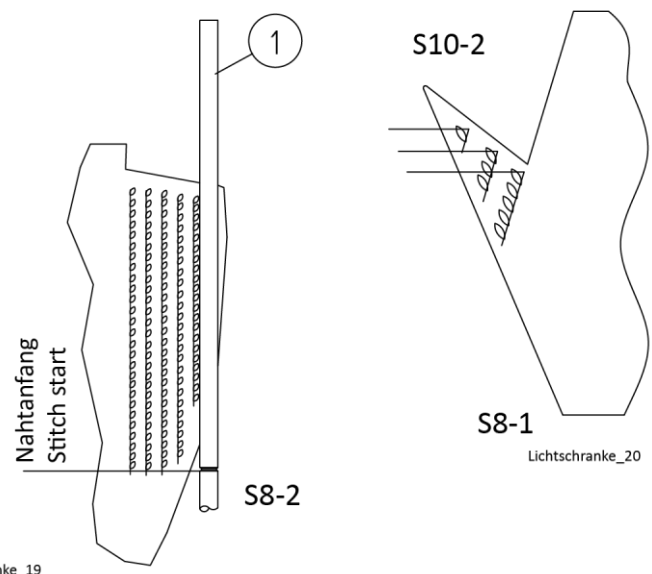

## Strobel-Switchable Functions - DC1500-AB221A

		Machine class		
		Setting range		KA-ED from version 22
Explanation: 0 = Off 1 = On				
F-290	Mode	00 37		33
F-291	Plug-in strip number for V810 operating control	00 14		01
"V810 operating control"	Button "1" left arrow	0 1		0
	Button "2" left arrow	0 1		0
	Button "4" left arrow	0 1		0
Stand: 28.10.2019 - PT_AB221A_KA-ED_191028				

## Strobel-Parameter list - DC1500-AB221A

		Machine class			
		Setting range	Unit	KA-ED from version 22	X = These parameters are not allowed be adjusted
F-290	Mode	00 37		33	<b>X</b>
F-291	Plug-in strip number for V810 operating control	00 14		01	
F-110	Positioning speed	070 390	min-1	390	<b>X</b>
F-602	Operating option	0 1		0	
F-604	Laserpositioning OFF / ON	0 1		0	
F-701	Sewing speed	0400 3000	min-1	2800	
F-702	Carriage speed	2000 5000	min-1	4500	
F-721	Balance stitches until the thread monitor becomes active	0 256	stitches	3	
F-722	Number of remaining stitches when thread brakes	0 256	stitches	3	<b>X</b>
F-751	Delay time Open clamping device t2	0100 1000	ms	0500	
F-752	Reverse stitches Driving in - driving out Stc1	05 20	stitches	10	<b>X</b>
F-753	Maximum driving in stitches Stc2	40 90	stitches	70	<b>X</b>
F-754	Delay stitches Stitch end Stc3	0 5	stitches	0	
F-755	Delay time Stitch beginning t3	000 100	ms	000	
F-756	Response time Error message t0	2000 5000	ms	2500	<b>X</b>
F-750	Minimum delay time Button activation t1	0100 1000	ms	0500	

Stand: 28.10.2019 - PT\_AB221A\_KA-ED\_191028

# Und wir können noch mehr für Sie tun!

Unser Lieferprogramm bietet für jede Branche und jegliche Anforderung genau die richtige Problemlösung.

## *And we can do a lot more for you!*

*Our range offers the correct problem solution for every branch and for all requirements.*

### ■ Für die Bekleidungsindustrie:

Ein- und Zweifaden-Hochleistungs-Saummaschinen

Doppelblindstich-Saummaschinen

Zweifaden-Blindstich-Staffiermaschinen

Roll- und Flachpikiermaschinen

Pikier-Automat

und

weitere Spezial-Nähmaschinen

### ■ *For the clothing industry:*

*Single and two thread high performance hemming machines*

*Bluff edge hemming machines*

*Two thread blind stitch felling machines*

*Roll and flat padding machines*

*Automatic lapel padding machine*

*and other special sewing machines*

### ■ Für die Schuhverarbeitung:

Einfaden-Überwendlichmaschinen mit und ohne Differentialtransport

### ■ *For the shoe industry:*

*Single-thread overseaming machines with and without differential feed*

### ■ Für Kürschnereien und Pelzkonfektion:

Pelzschnellnäher

### ■ *For the fur industry:*

*High-speed fur sewing machines*

### ■ Für Heimtextilien:

Ein- und Zweifaden-Blindstichmaschinen

### ■ *For the home textiles industry:*

*Single and two thread blind stitch machines*

### ■ Für die Polsterverarbeitung:

Ein- und Zweifaden-Überwendlichmaschinen

Ein- und Zweifaden-Blindstichmaschinen

### ■ *For the upholstery industry:*

*Single and two thread overseaming machines*

*Single and two thread blind stitch machines*

### ■ Für die Konfektion technischer Textilien:

Ein- und Zweifaden-Überwendlichmaschinen

### ■ *For the processing of technical textiles:*

*Single and two thread overseaming machines*

## Noch Fragen?

Dann rufen Sie uns an, schreiben Sie uns oder kommen Sie einfach bei uns vorbei.

Sie können jederzeit weitere Informationen über unsere Produkte anfordern oder die Strobel-Nähmaschinen in unserem Ausstellungsraum live erleben. Wir freuen uns auf Sie!

## *Any further questions?*

*Then phone, write or simply come and see us. You can have further information about our products at any time, or experience the Strobel machines live in our show room. We're looking forward to meeting you!*

***STROBEL***

**Spezialmaschinen GmbH**

Postfach 1242  
82168 Puchheim  
Boschstraße 16  
82178 Puchheim  
DEUTSCHLAND

[www.strobel.biz](http://www.strobel.biz)  
Telefon: +49 89 80096-0  
Telefax: +49 89 80096-190