

For the professional user

Operating Instructions

Für den professionellen Anwender

Betriebsanleitung

Class: VEB100-3
Klasse:

Model: 4
Ausführung:

Dated:
Stand:

The sign of quality



You find the Strobel trademark on every Strobel machine leaving our works. And with good reason. This symbol is a guarantee of the high quality of our products. Quality which creates trust – trust in our technology, our service and, not least of all, in our good name.

Im Zeichen der Qualität

Sie finden die Strobel-Schutzmarke auf jeder Strobel-Maschine, die unser Werk verlässt. Und das aus gutem Grund. Denn dieses Zeichen garantiert Ihnen die hohe Qualität unserer Produkte. Qualität, die Vertrauen schafft – in unsere Technik, unseren Service und nicht zuletzt in unseren guten Namen.

Strobel clients know that they can expect a particularly high standard of performance from our company and our machines. Now you have settled for one of our products. For us this is a source of encouragement and of obligation to Justify your trust.

If you wish to profit from the performance and efficiency of your Strobel machine as long as possible, exact handling and thorough care is necessary. For this reason we kindly request that you read the operating instructions closely.

It provides all the information you need for trouble free operation.

And if you do happen to need a spare part the enclosed spare parts list gives a complete overview. It is clearly classified according to components so that you can find the required part quickly and easily. In order to avoid errors we request you to quote machine class, machine number and part number completely on your spare part order.

We wish you lots of success in your work with your new Strobel machine.

Unterseite/underside

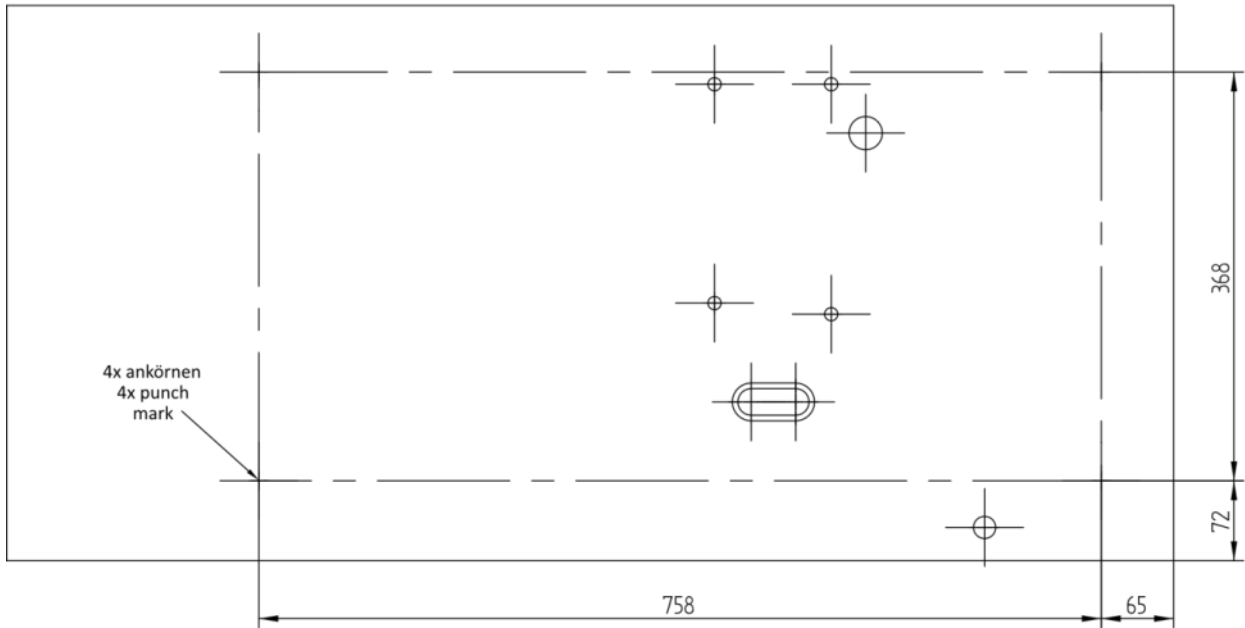

Oberseite/upper side

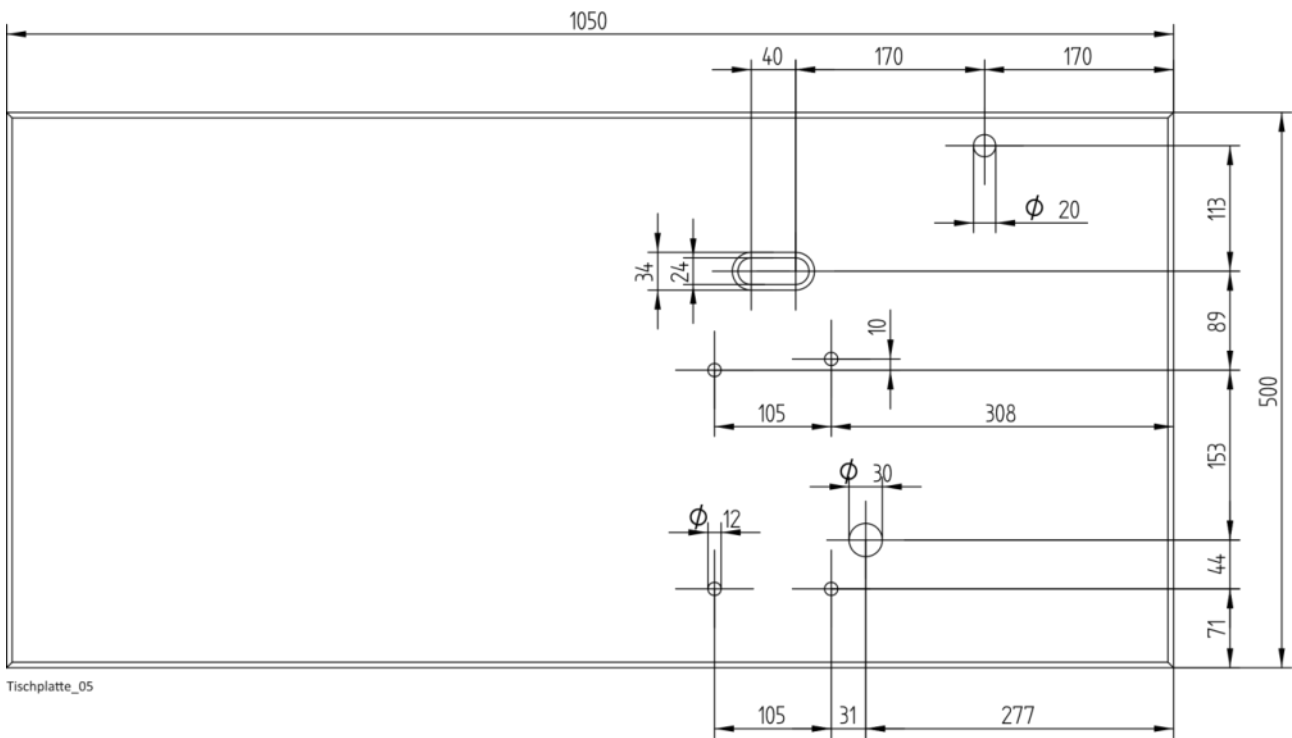

Tischplatte_05

Operating instructions STROBEL Class VEB100-3

Contents

1	General notes on safety	5
2	General	7
2.1	Operating instructions	7
2.2	Class description, serial number and initial basis for description	7
2.3	Range of application and intended use	7
2.4	Power supply.....	8
2.4.1	General notes.....	8
2.5	Function sequence, machine class and operating concept.....	8
2.5.1	General function sequence.....	8
2.6	Technical data	9
3	Installation and putting into service	11
3.1	Unpacking the machine	11
3.2	Installation	11
3.3	Sense of rotation.....	13
3.4	Motor drive via Toothed belt	13
3.4.1	Tensioning the Toothed belt (Fig. 1)	13
3.4.2	Positions of the machine	14
4	Instructions for use.....	16
4.1	Needles and threads	16
4.2	Inserting the needle (Fig. 4)	17
4.3	Threading and thread course.....	18
4.4	Thread tension	18
4.5	Thread take-up lever.....	19
4.6	Stitch depth control	19
4.6.1	Setting the stitch depth	19
4.7	Cloth retainer (Fig. 7)	20
4.7.1	Setting the plunger limit stop for sewing over cross seams (Fig. 7)	21
4.7.2	Setting the automatic plunger	21
4.8	Material feed.....	22
4.8.1	Setting the stitch length (Fig. 8)	22
4.8.2	Setting the top feed	23
4.9	Sewing drive	23
5	Operating the machine.....	24
5.1	Switching on	24
5.2	Operating and function of the control	25
5.2.1	General.....	25

5.3	Placing and removing the fabric - sewing process	27
5.4	Soft start and Sewing foot lifting	28
5.5	Calibrate pedal	29
5.5.1	Change pedal steps	30
5.5.2	Change speed curve	31
5.6	Sewing	31
5.6.1	Waistband lining - Staffing with blindstitch	32
5.6.2	Attaching the trouser waistband lining (Fig. 15)	33
5.7	Sewing lamp	34
5.7.1	General notes	34
6	Problems during sewing and possible solutions	36
7	Machine maintenance	39
7.1	General	39
8	Variable sewing tools	39
9	Optional extras	41
9.1	Thread trimmer	41
9.2	Digital display 392.0637	41
9.3	Pneumatic lifting	41

Subject to change without prior notice

1 General notes on safety

Manuals and additional information can be found on the STROBEL website at:

<http://www.strobel.biz>

Every person in charge of setting up, operating, servicing and repairing the machine must first read and understand the operating instructions and particularly the safety instructions before starting up the machine.

Failure to comply with the following safety instructions can lead to physical injuries or damage to the machine.

1. The machine must only be operated by persons familiar with the relevant operating instructions and who have been instructed accordingly.
2. Before commissioning also read the notes on safety and the operating instructions of the sewing drive manufacturer.
3. Only use the machine in the intended manner and never without the provided guards. Always observe the pertinent safety regulations.
4. Switch off the main switch or pull the power plug for threading, changing the bobbin, exchanging sewing tools such as needle, hook, stitch plate, transport devices, trimming knife and cutting block, for cleaning and when leaving the workplace as well as for maintenance.
5. General maintenance tasks may be carried out only by properly trained persons in accordance with the operating instructions.
6. Repair work, retrofitting and maintenance may be carried out only by technicians or specially trained personnel.
7. When servicing or repairing pneumatic equipment, the machine must be disconnected from the pneumatic supply. Exceptions are only allowed for adjustment work and tests of functionality performed by specially trained technicians.
8. Only specially qualified technicians may work on the electrical equipment.
9. It is forbidden to work on electrically live components! Exemptions are covered by the EN50110 (DIN VDE0105) regulations.
10. Any retrofitting or alterations to the machine may only be performed under strict compliance with all pertinent safety regulations.
11. Only use our approved spare parts when servicing and/or repairing the machine.
12. It is forbidden to operate the sewing head until it is determined that the entire sewing unit complies with EU provisions.

13. It is essential that you observe and follow these instructions as well as the generally valid safety regulations.
14. Warning instructions given in the operating instructions that pertain to especially dangerous parts of the machine must be indicated at these positions using a safety symbol.



Warning instructions given in the operating instructions that pertain to special injury hazards for operating personnel or technicians must be indicated at these positions using a safety symbol.



2 General

2.1 Operating instructions

Any person involved in the installation, operation, maintenance and repair of the machine must have read and understood the operating instructions and mainly the safety instructions before starting the machine. Please open the illustrations at the beginning of these operating instructions, so you can follow the illustrations step by step while reading the instructions.

2.2 Class description, serial number and initial basis for description

For side-referenced descriptions, the operating side of the machine is the starting base.

The class descriptions (type), the serial and model number (after the hyphen) can be found on the rating plate on the back of the machine.

2.3 Range of application and intended use

The Class VEB100-3 is used for sewing the waistband lining of trousers, also for waistband processing with closed belt loops already sewn on.

Exchanging the variable sewing tools, i.e., can extend the range of applications of the different machines that other fabric qualities than the above mentioned ones could be sewn as well.

Variable sewing tools please see point 8.

2.4 Power supply

2.4.1 General notes

	<p>CAUTION!</p> <p>Work on the sewing machine's electrical equipment or sewing drive may only be done by electricians!</p> <p>There is the DANGER of a fatal electrical shock.</p> <p>When working on the electrical equipment, the machine with the S1 power switch has to be switched off and the power plug pulled out!</p> <p>The operating instructions (including safety instructions) of the sewing machine and sewing drive must be observed!</p>
---	---

2.5 Function sequence, machine class and operating concept













2.5.1 General function sequence

The DAC Classic control contains the suitable function sequence for almost all VEB machine classes.

The exact function sequence for a machine class is determined at the control by the function sequence (basic function sequence and machine selection), the function parameters and the switchable functions. The control is optimally control-technically adapted to the respective machine class by correct settings.

On delivery, all function parameters and functions are already set correctly.

2.6 Technical data

	Empfohlene Nennstichzahl / Recommended rated speed	1800 min-1
	Stichlänge / stitch length	3,0 - 7,0 mm (abhängig vom Nähmaterial / depend on fabric) Auslieferungszustand / delivery condition 7,0 mm
	Obertransport / top feed Untertransport / bottom feed	Pyramidenverzahnung / pyramid toothing Bandtransport / Beltfeed
	gefederter Taucher / spring loaded plunger	
	Stichplattenöffnung / stitch plate opening	7,0 mm
	Stichtiefenanzeige / stitch depth display	digital display optional
	Nadelsystem / needle system Nadelstärke / needle size	GROZ-BECKERT 1669 EEO 90/14
	Fadenabschneider / thread trimmer	optional
	Fadenspannung / thread tension Faden / thread	Auslieferungszustand / delivery condition 30 cN Polyester, endlos gezwirnt / polyester continuous filament 120/2
	Durchgangsraum / arm space	70 mm
	Abschwenkbare Arbeitsplatte / swing away workplate	
	LED Leuchte / LED sewing lamp	

Technischer Auslieferungszustand / delivery condition	
Riemenscheibendurchmesser Maschine/ machine pulley diameter	dw 80 mm
Motor-Leistung min. / min. motor power	500 W
Keilriemen-Profil / V-belt profile	10 x 6 mm
Zahnriemenscheibe Maschine / toothed belt pulley/machine	Z = 38
Zahnriemenprofil / toothed belt profile	HTD 5M-9
Stichart / stitch type	Einfaden-Kettenstich-Blindstich Typ 103 / single thread chain stitch type 103
Anschluss pneumatisch / pneumatic connection	6 bar
Luftverbrauch, Mittelwert / average air consumption	abhängig von der Ausstattung / depending on the equipment
Stellfläche / foot print	0,5 m x 1,1 m
Arbeitsgeräusch / operating noise at 2200 min-1 nach DIN 45635-48-1 KL3	LpAm 71 dB(A)

3 Installation and putting into service

3.1 Unpacking the machine

Strobel machines are delivered either complete or as a machine head with sewing drive.

Reel stand, rods and other accessories are packed into the packing.

Make sure that all accessories have been unpacked before throwing away any packing material.

3.2 Installation



CAUTION ! Danger of injury!

Entanglement hazard for clothing or hair and **Danger** of finger injuries!

Never operate the machine without the belt guards for the upper part and Sewing drive.

If the machine head is supplied without stand first make the borings into the table top as shown in the drawing. Mount rods and treadles and electric connections according to the connecting diagram.

The upper component must be fastened to the provided rubber plate on the table top.

Mount the lifting and sewing drive operating rods.

Using a compact motor means to assemble the control box and speed controller under the table. Also the operating rod between speed controller and pedal has to be connected.

After assembling the single parts of the reel stand mount it to the right hand side of the tabletop.

Make sure that all screws on the stand are tight and retighten them, if necessary.



A T T E N T I O N !

Before putting the machine into service make sure that the electric connecting data on the sewing drive's name plate, mainly voltage and frequency, correspond to your electric network.



A T T E N T I O N !

The maintenance instructions according to the operating instructions must be followed!

3.3 Sense of rotation

The correct sense of rotation of the hand wheel is clockwise in line of vision on the hand wheel.

3.4 Motor drive via Toothed belt

3.4.1 Tensioning the Toothed belt (Fig. 1)



CAUTION ! Danger of Injury!

Switch off the machine at the mains when checking the belt tension. Do not operate the machine without belt guard. Otherwise DANGER of crushing fingers, of injuries to the body or of pulling in of part of clothing.

The toothed belt should not be tensioned too much. You should be able to compress it with light thumb pressure by about 5 mm.

Too little or too tight toothed belt tensioning can impair the positioning of the machine and therefore impair the function sequence.

Tensioning the toothed belt (Fig. 1):

- Release the upper and the bottom retaining screw (1), (2) at the upper part of the machine.
- Pull out the sewing drive slightly and tighten the bottom retaining screw (2) slightly.
- Tension the toothed belt by swivelling the sewing drive.
- Tighten the upper and the bottom retaining screw (1), (2) again.

Fig. 1

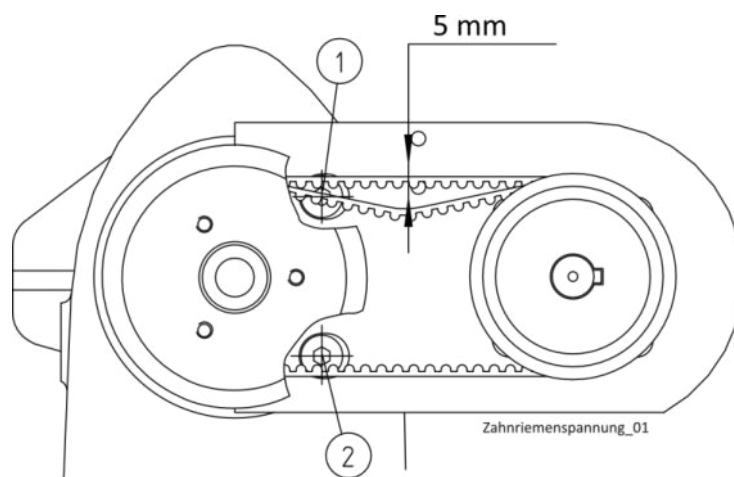

3.4.2 Positions of the machine



CAUTION ! Danger of Injury!

Danger of pulling in parts of clothing and of hair and **danger** of crushing fingers and stitching fingers with needles!
When checking positions with switched-on machine keep fingers and hands away from moving parts.

Machine with or without thread trimmer:

The machine needs a needle position and a reference position.

Reference position t 08 10:

The reference position must be set in such a way, that the point of the needle in direction of the insertion stitch closes with the right (inner) edge of the needle slide plate.

Fig. 2

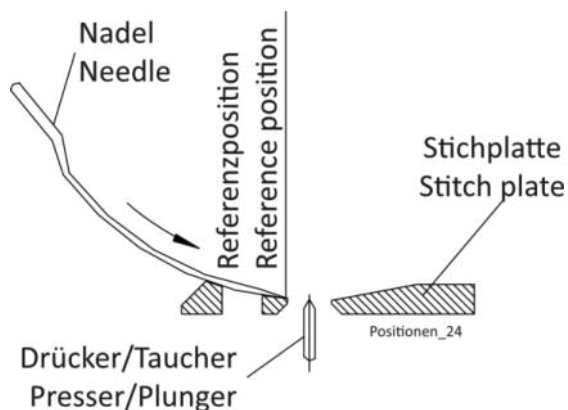

Cutting position t 08 13 (Fig. 3):

The needle position must be set in such a way, that when the machine is stopped, the hook of the thread knife catches the thread loop lying over the looper securely without touching the looper.

Fig. 3

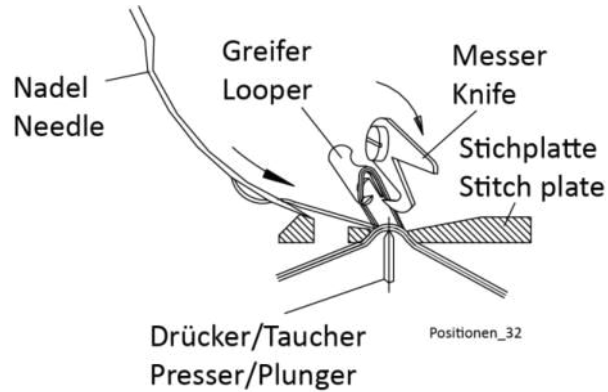

For the VEB machines we set t 08 12 to the same value as t 08 13/cutting position.

This allows us to disregard the needle position after sewing stop key!

For Strobel, the key "needle position after sewing stop" must be switched on as soon as t 08 12 has a different value than t 08 13!

4 Instructions for use

4.1 Needles and threads

The sewing quality can be influenced to a considerable extent by choosing the most suitable needles and threads for the material to be sewn. It is recommended to use controlled GROZ-BECKERT needles system 1669 EEO only.

The machine is delivered with needles of size 90/14.

NOTICE: A perfect needle is of great importance for a good sewing result. Damages of the needlepoint, which often can be made visible under a magnifier, only may deteriorate the sewing result. Replace the needle in time!

We recommend twisted polyester filament threads of size 120/2 respectively. Because of their high strength and ability to slide, combined with a low volume they are to be preferred over a spun thread.



G u a r a n t e e d r e m a r k !

This machine has been set and sewn off with **genuine GROZ-BECKERT needles**.

No guarantee can be granted if the settings are modified for using other needle types.

4.2 Inserting the needle (Fig. 4)



CAUTION ! Danger of Injury!

Before replacing the needle, switch off the machine electrically, and depress the motor switch pedal to make sure that the machine is truly switched off.

Otherwise there is a **danger of injury** from crushing and needle punctures.

The curved needle (1) shape determines its position in the needle lever (2). Attention should be paid only to ensure that the needle piston is pushed to the stop in the channel of the needle lever (3) and that the screw (4) of the needle clamping plate (3) is tightened well.

Fig. 4

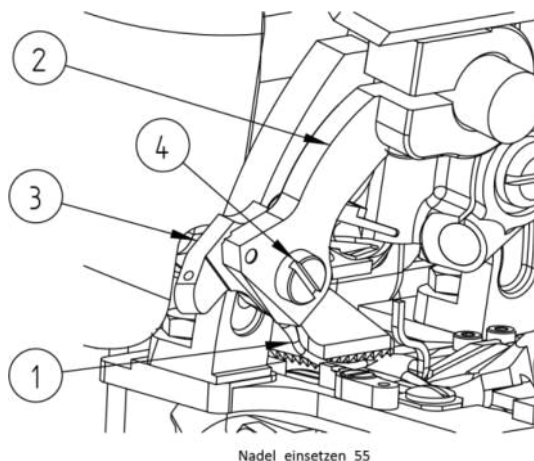

4.3 Threading and thread course



CAUTION! Danger of Injury!

Switch off machine electrically and confirm that the machine is really in standstill position by operating the treadle for the sewing drive control before threading.

Fig. 5 shows the correct threading by using the thread take-up.

Fig. 5

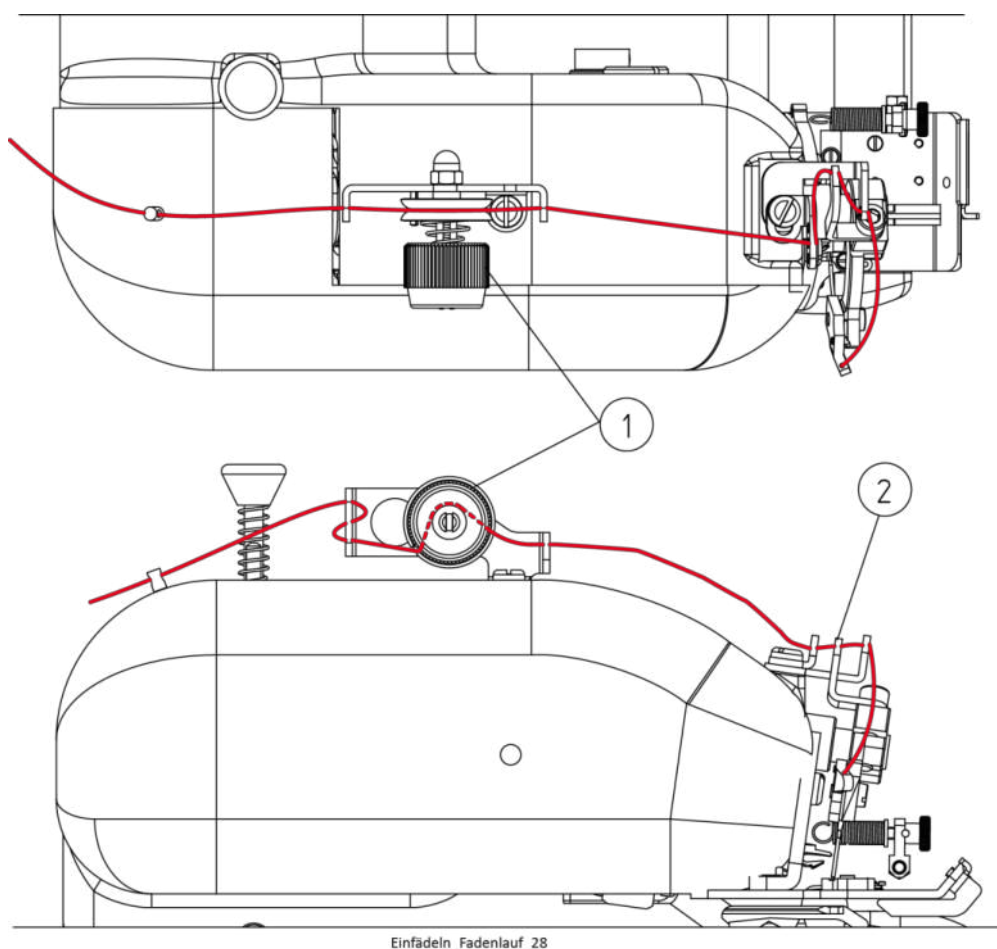

4.4 Thread tension

Depending on thread and fabric quality, nature and thickness the thread tension is set by tension nut (1) (Fig. 5).

4.5 Thread take-up lever

The thread take-up lever (2) (Fig. 5) avoids thread twist and turning over of the loop, thus enabling a secure taking up of the loop by looper and needle. There is a uniform stitch formation and the hem edge is free of pucker.

The function of the thread take-up lever is influenced by the thread course (choice of the eyelet).

4.6 Stitch depth control

By means of the stitch depth control you can adjust the distance between the upper edge of the plunger and the needle radius, i.e. the distance the plunger is lifted or lowered depending on the material thickness. This determines the depth the needle penetrates the fabric layers held between plunger and cloth retainer. This value is called stitch depth.

4.6.1 Setting the stitch depth

The stitch depth is set using the control button ((1) Fig. 6) and is located on the front side of the machine.

- ⇒ Turn the control button to the left (+) to create a deeper stitch.
- ⇒ Turn the control button to the right (-) to create a less stitch depth insertion.

Fig. 6

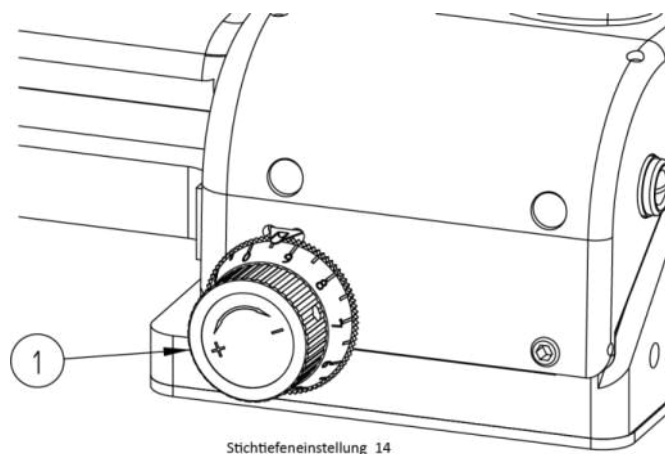

4.7 Cloth retainer (Fig. 7)

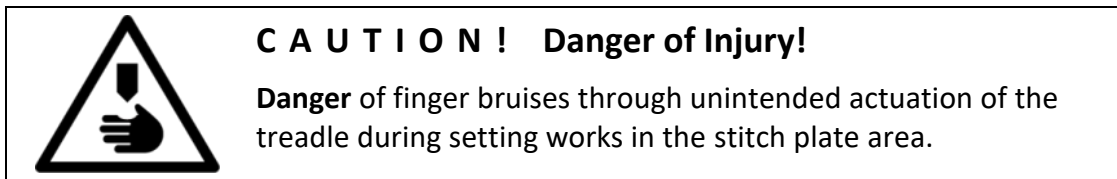

The stitch plate is upped with a cloth retainer (1) which holds the fabric on the plunger during the time of needle penetration.

The cloth retainer in machines equipped with a spring-loaded plunger is combined with an adjusting screw which limits the cloth retainer's upwards stroke. (2)

This combination is called plunger limit stop. Plunger limit stop and the spring-loaded plunger prevent the needle from stitching through the material over cross seams and other thicker parts and avoid markings.

Fig. 7

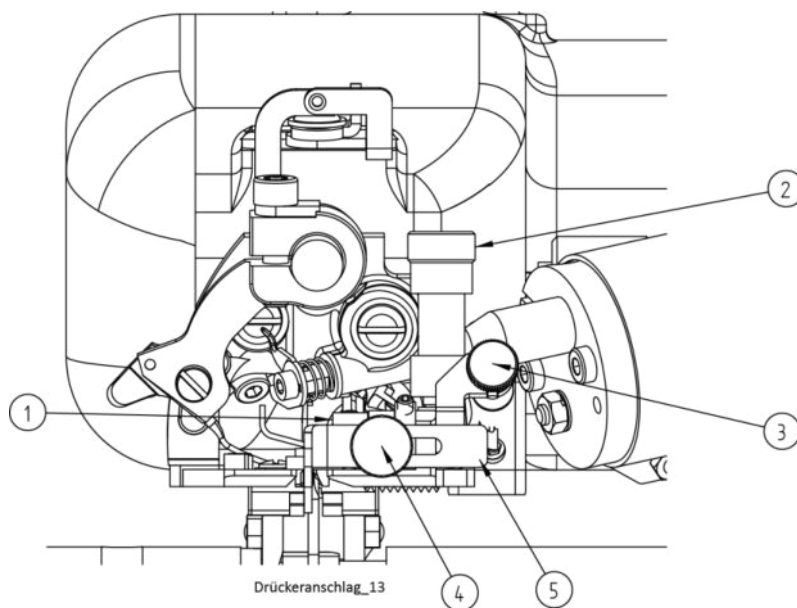

4.7.1 Setting the plunger limit stop for sewing over cross seams (Fig. 7)

The cloth retainer stroke is set by means of a knurled nut (2), which serves as upper limit stop. To set the stroke place the material (a normal fabric layer without cross seam). Close the cloth support arm and turn the hand wheel manually until the needle penetrates the fabric. In this position there should be nearly no space between cloth retainer and fabric layer. If the setting is correct the automatic plunger should be compensating the cross seams, so that the needle does not penetrate the outer layer.

The pressure of the cloth retainer on the fabric layers or the hem edge can be adjusted through turning the knurled nut (3). The pressure should be as low as possible to avoid twist or marks resulting from the pressure between plunger and cloth retainer, mainly when sewing delicate fabrics as e.g. velvet. However, the pressure should be high enough to keep the material between plunger and cloth retainer during the time of needle penetration.

The setting of the plunger limit stop has a considerable influence on the stitch quality.

4.7.2 Setting the automatic plunger

The spring pressure of the automatic plunger is set at works and usually needs not to be altered. If the plunger limit stop is set correctly over cross seams the needle should not penetrate the outer fabric layers.

For plunger settings please refer to the mechanic's instructions.

4.8 Material feed

The machine transports the sewing material with a fixed top transport and with a bottom tape feed dog. The feed (stitch length) can be set from 3 - 7 mm in 4 steps. Serially, a pyramid toothed feed dog is mounted (see point „8 Variable sewing tools“).

4.8.1 Setting the stitch length (Fig. 8)



A T T E N T I O N !

Switch off machine electrically and make sure that the machine is really in standstill position by operating the treadle for the sewing drive control.

Press stitch adjusting knob (1) and turn the hand wheel until the adjusting knob catches.

Keep the stitch-adjusting knob pressed and turn the hand wheel to the front until the desired stitch length catches.

Fig. 8

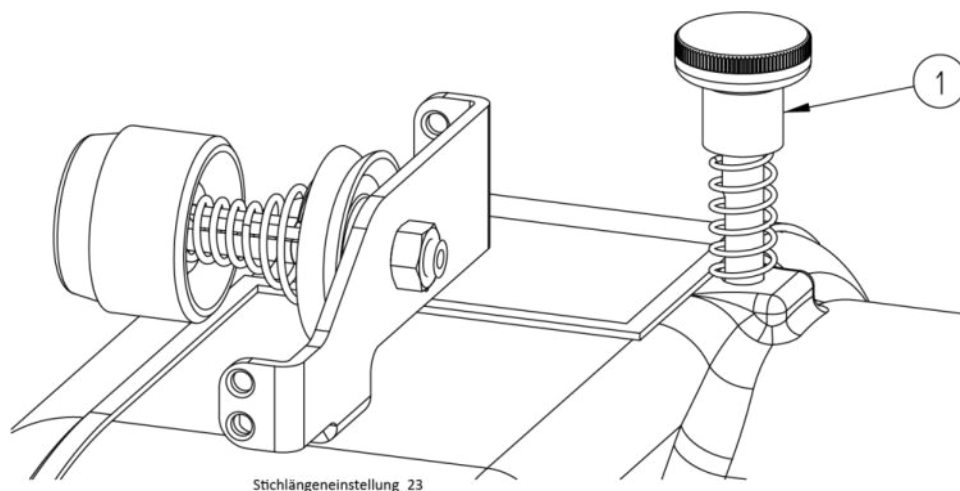

Stichlängeneinstellung_23

4.8.2 Setting the top feed

The feed dog can be adjusted in its intrusion depth to the stitch plate by loosening the two fastening screws. If the stitch length is adjusted across a greater range, e.g. from 7 to 3, then the feed dog should be readjusted.

Also when the fabric thickness or quality changes it is recommended to re-adjust the feed dog.

Please refer to the mechanic's instructions.

4.9 Sewing drive

General:

A DA432 sewing drive is available to drive the sewing machine.

Please note the instructions available online. There you find notes and the instructions for programming the control including the motor speed adjustments.

5 Operating the machine

It is recommended to equip the machine with a pneumatic lifting device to facilitate machine handling (please see "9.3 Pneumatic lifting").



CAUTION ! Danger of Injury!

Please observe the sewing area carefully during sewing.

Otherwise there is a **danger of injury** from crushing and needle punctures.

5.1 Switching on

Connect the compressed-air conditioner to the compressed air supplier (max. 10 bar) or to the compressor and set it to 6 bars. Switch on main switch on the right hand side under the table top. Control lamp "POWER" is green.

5.2 Operating and function of the control

5.2.1 General

The control is switched on and off by the power switch, which is located on the right side of the machine, below the tabletop (Fig. 9).

Fig. 9

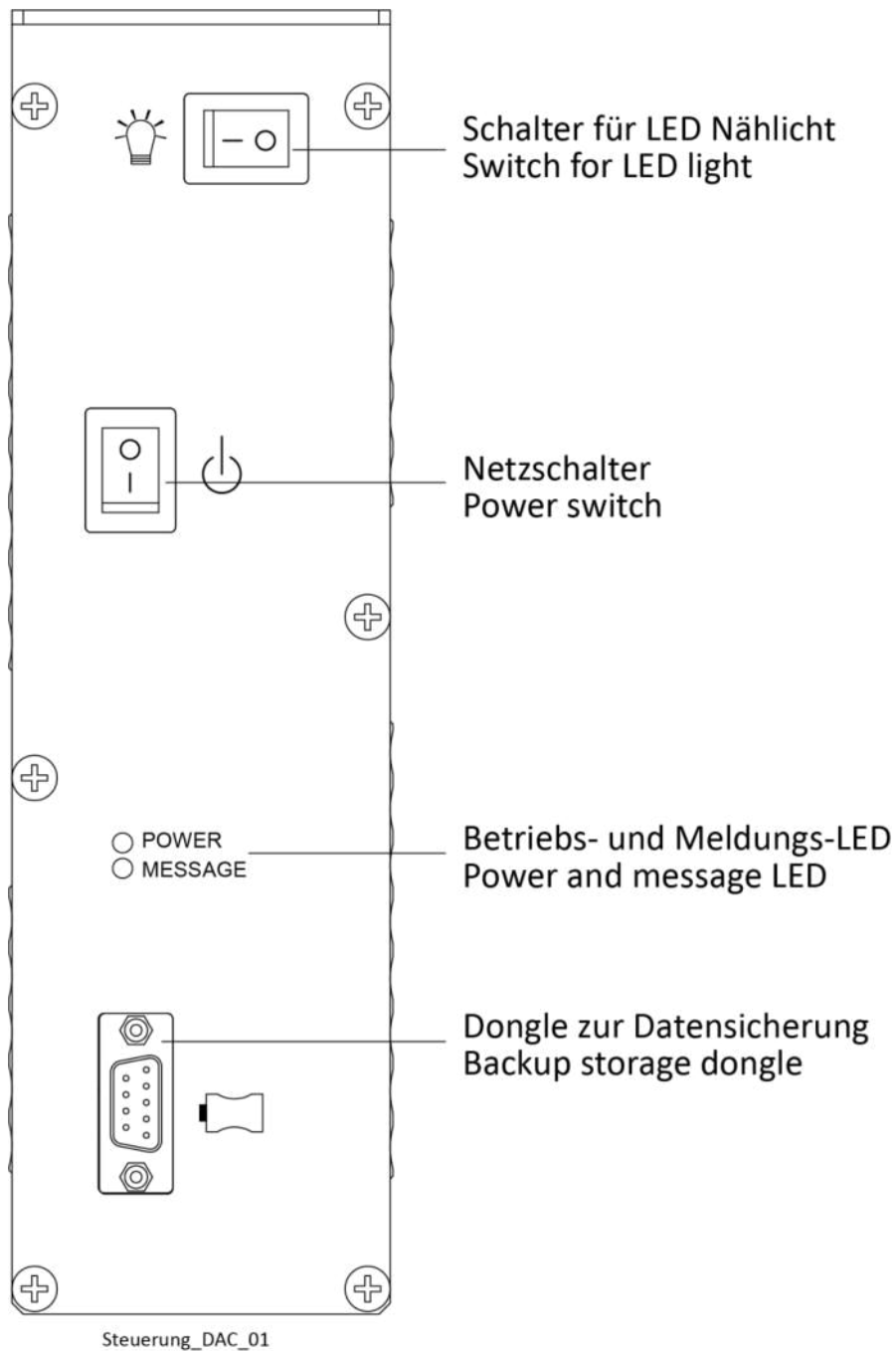

Assignment and display of button functions on operating control V810 (Fig. 10)

Fig. 10

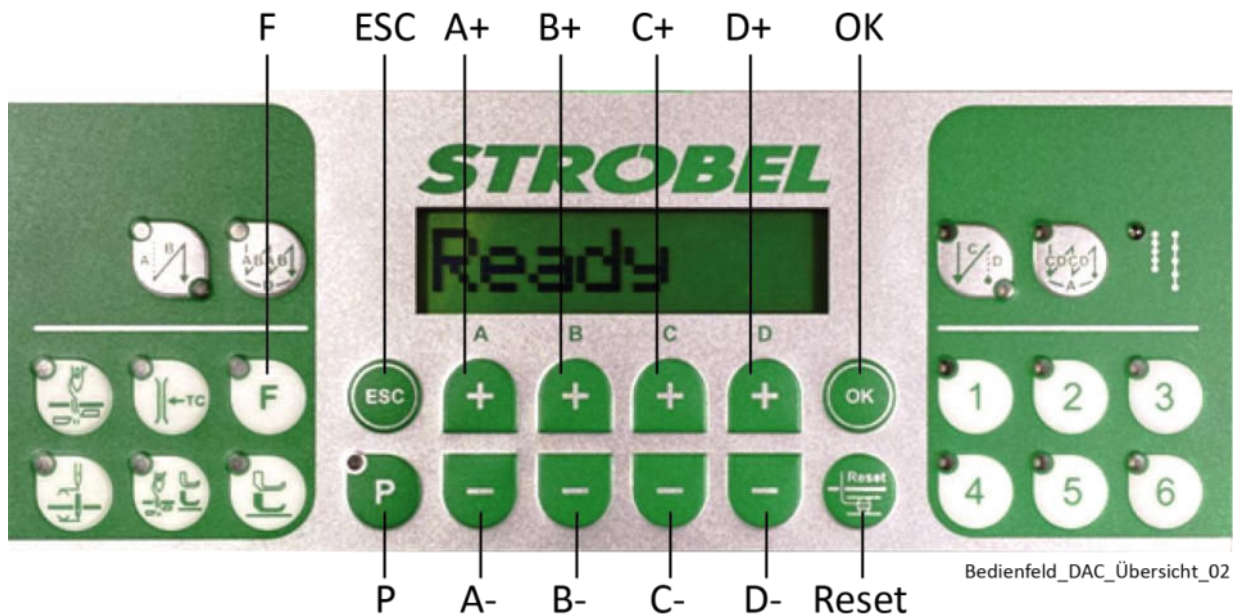

F	Function key Activates or deactivates any stored function
ESC	Exits the setting mode
A+/-	Increase/reduce parameters Switches user level Selects sub-programme
B+/-	Increase/reduce parameters Switches to next higher category Selects sub-programme
C+/-	Increase/reduce parameters Selects sub-programme
D+/-	Increase/reduce parameters Selects sub-programme
OK	Recalls or saves parameters
P	Starts or ends the setting mode Saves the setting values
Reset	To enter the technician level, press the "P" and "Reset" keys simultaneously.

5.3 Placing and removing the fabric - sewing process

- Knee lever lifting

Lift the cloth support arm by pressing the knee lever.

Place the fabric under the stitch plate and release the pedal.

Press the pedal to start sewing.

When the pedal is depressed, the machine runs at the set maximum speed.
(please see "4.9 Sewing drive").

- Pneumatic lifting (optional extra)

Fig. 13 shows the treadle's switching functions when the machine is equipped with pneumatic lifting. Place the fabric under the stitch plate while the cloth support arm is lifted and close the arm by slightly pressing the treadle (+1).

The machine is now ready to sew.

If the fabric is not placed correctly, the cloth support arm can be lifted again by heeling the treadle back into its initial position. At the end of the sewing process the thread trimmer (optional extra) is operated and the cloth support arm is lifted by heeling the treadle (-1).

5.4 Soft start and Sewing foot lifting

Soft start

Fig. 11



Light at no. 1 is on, soft start is active. Number of softstart stitches can be set with t 05 01. 2 stitches are the basic setting. Light at no. 1 is off, softstart is deactivated.

Sewing foot lifting

Fig. 12



Light is on, the fabric support arm remains open after the end of sewing and after releasing the pedal position -2.
Light is off, the fabric support arm closes after the end of sewing and as soon as the pedal position -2 is released.

5.5 Calibrate pedal

After mounting the setpoint adjuster, it is necessary to calibrate the pedal. In addition, a speed curve can be determined that influences the acceleration of the machine head. The speed curves refer to the set maximum speed, the minimum speed and the following pedal positions.

Fig. 13

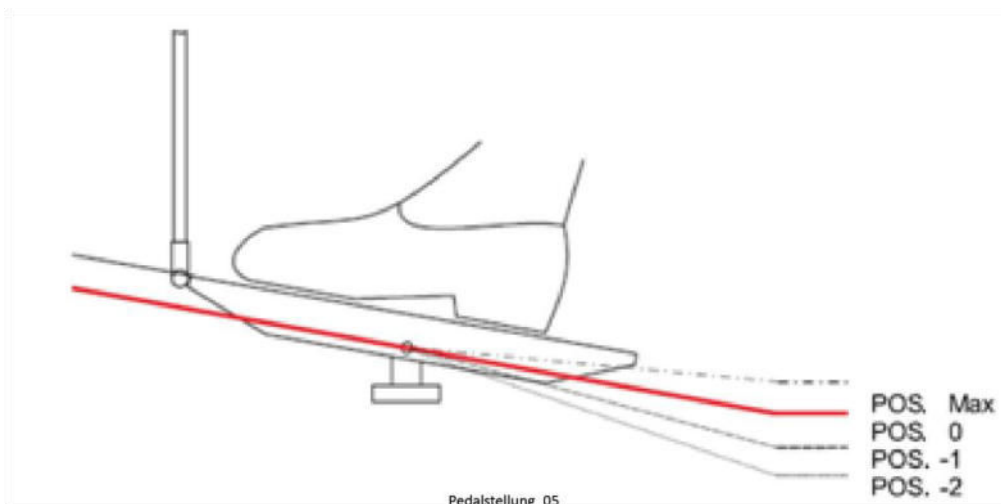

To calibrate the pedal:

1. Call up parameter **t 08 20**.
2. Press the "OK" button.
The LED of the "P" button flashes. The display shows "POS -2?"
3. Press the pedal to position -2.
4. Confirm with the "OK" button. The display shows "POS -1?"
5. Press the pedal to position -1.
6. Confirm with the "OK" button. The display shows "POS -0?"
7. Press the pedal to position -0.
8. Confirm with the "OK" button. The display shows "POS Max?"
9. Press the pedal all the way forward.
10. Press the "OK" button.
The display jumps back to parameter **t 08 20**.

You can navigate to the next parameter to change the pedal levels.

5.5.1 Change pedal steps

You can use pedal steps to specify how quickly the maximum speed is reached. The fewer pedal steps you specify, the faster you reach the maximum speed.

To change the pedal levels:

1. Call up parameter **t 08 21**.
2. Press the "OK" button.
The LED of the "P" button flashes. The display shows the currently set number of pedal steps.
3. Press the "D+" or "D-" key repeatedly until the desired number appears on the display.
4. Confirm with the "OK" button.

You can navigate to the next parameter to change the speed curve.

5.5.2 Change speed curve

To change the speed curve:

1. Call up parameter **t 08 22**.
2. Press the "OK" button.
The LED of the "P" button flashes. The display shows the value for the currently set speed curve. (Fig. 14)
If the desired value does not appear:
Press the "D+" key repeatedly until the desired value appears.
3. Confirm with the "OK" button.

If you do not want to make any further settings, exit the setting mode by pressing "ESC".

Fig. 14

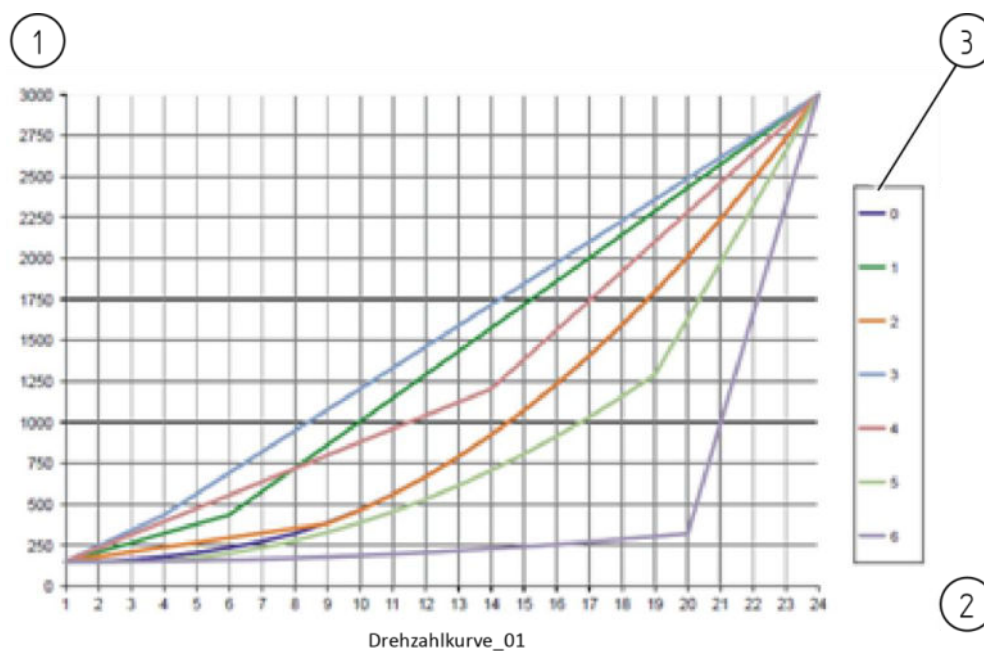

(1) Speed

(2) Pedal step

(3) Speed curve

5.6 Sewing

The machines of the VEB series are mainly designed for blind stitch hemming. The special applications of the corresponding subclasses are described under "2.3 Range of application and intended use".

The sewing result should be an elastic seam free of marks. Depending on fabric quality the sewing requires a certain skill. The following instructions will help the operator to obtain this skill.

5.6.1 Waistband lining - Staffing with blindstitch

If there are no former values available, proceed as follows:

- Set the desired stitch length.
- Set the stitch depth.
- Check the pressure of the cloth retainer and readjust it, if necessary.
- Set the limit stop of the plunger.
- Set the material guide by loosening screw (4) (Fig. 7) and displacing the material guide (5) to get the corresponding limit stop for the hem edge. You can sew at the hem edge or on the hem. See Fig. 15.
- Check the stitch length and readjust the feed dog, if necessary.
- Set the thread tension.
- Re-thread to obtain a better seam appearance.

Place the material and make sure that the feed dog can catch the beginning of the seam after the first stitch.

Operate the treadle briefly. Go on sewing or, if necessary, change a.m. settings until you get the desired result.

Readjust the stitch depth regulation if the stitches show through on the outer fabric side.

Sometimes certain "marks" caused by the needle penetration on the outside of the fabric cannot be avoided when the fabric is extremely thin or hard.

Make sure that during sewing the hem edge is always guided along the material guide. Avoid sudden treadle operations since speed changes during the sewing process may influence the needle penetration.

5.6.2 Attaching the trouser waistband lining (Fig. 15)

For this operation a stitch plate with wide opening is recommended since usually different fabric layers have to be sewn.

Recommended needle sizes: 80/12, 90/14

There are two different types of operations (Fig. 15a and Fig. 15b):

- a) sewing the waistband on the lining
- b) sewing the waistband on the edge

Fig. 15

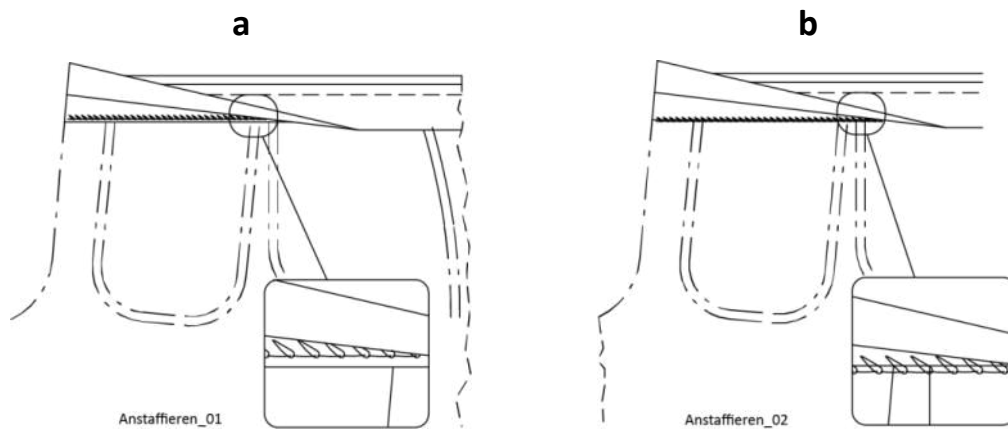

5.7 Sewing lamp

5.7.1 General notes

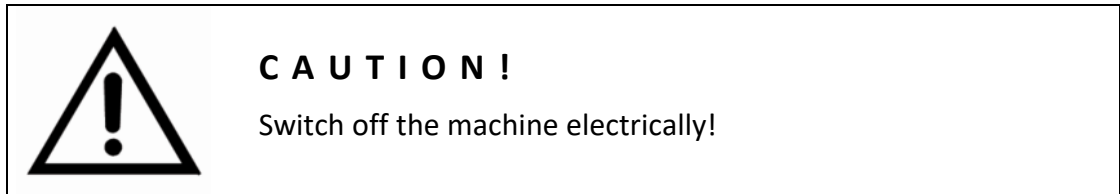
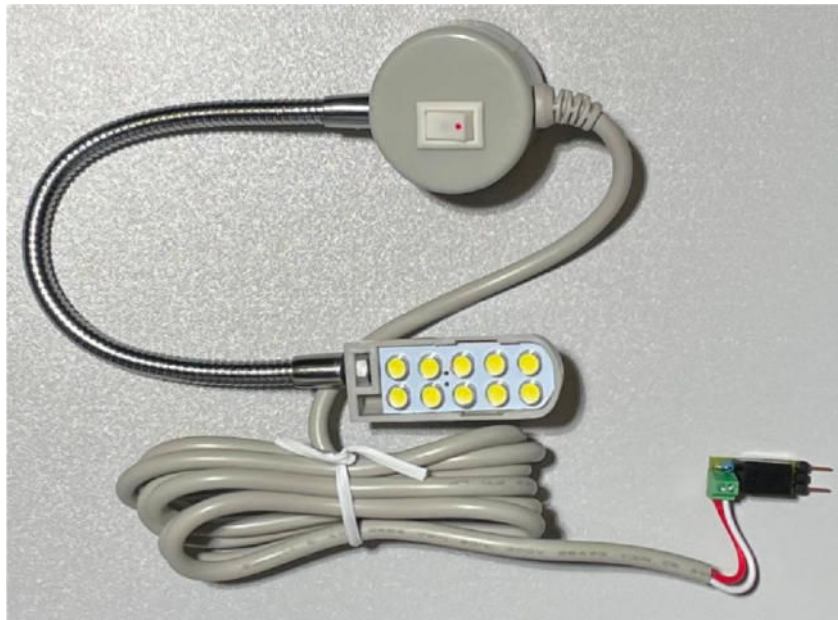

Fig. 16



Nähleuchte_03

For self-assembly with stand see Fig. 17

Fig. 17

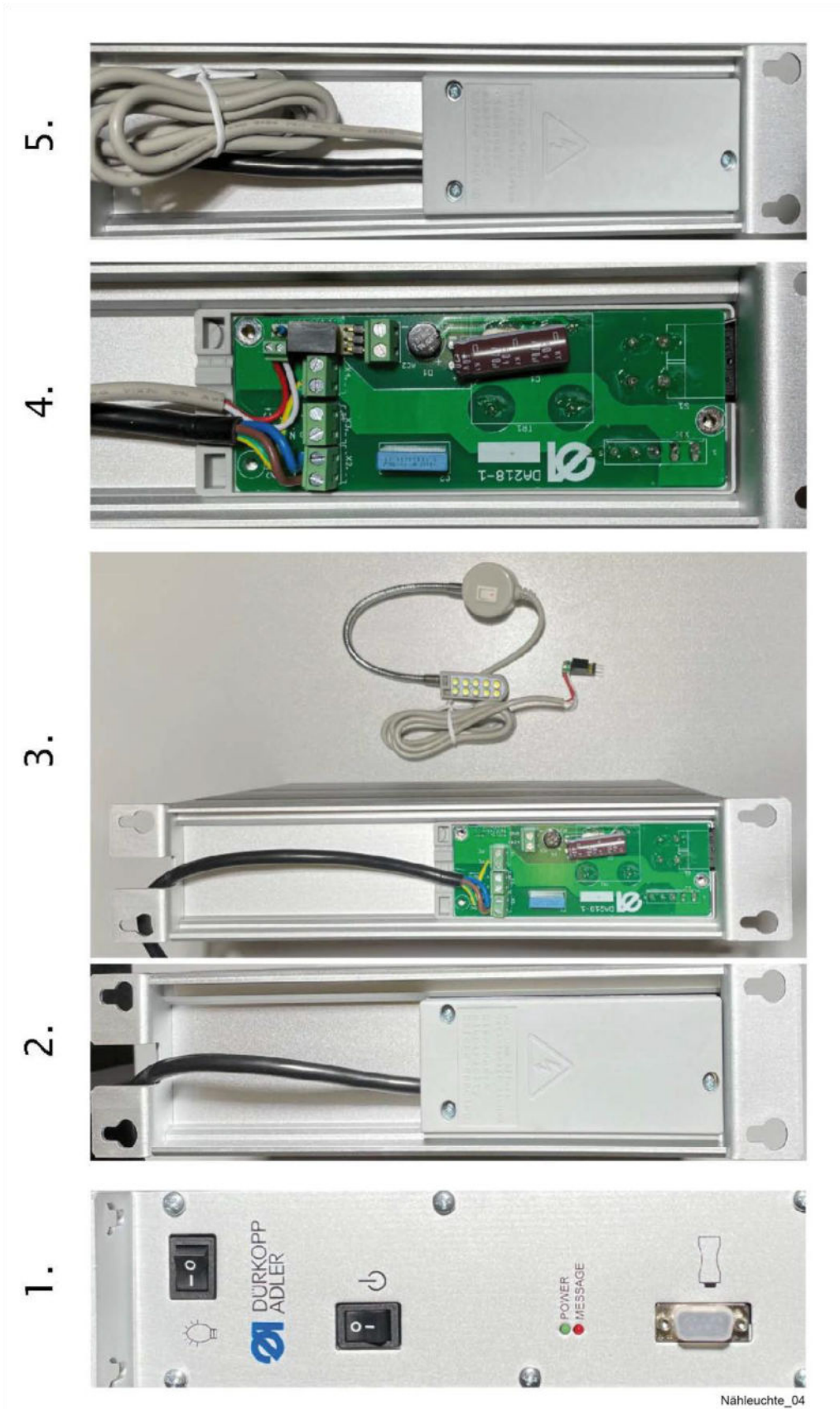

6 Problems during sewing and possible solutions



CAUTION ! Danger of Injury!

Switch off machine electrically and confirm that the machine is really in standstill position by operating the treadle for the sewing drive control.

Otherwise there is a **danger of injury** from crushing and needle punctures.

● **Thread tears**

Possible reasons:

- sharp edges or grooves in the needle guide, thread take-up, looper or needle eye after a long time of machine operation
- looper or loop stroke are not set correctly, therefore the thread loop is not always caught
- thread tension set too high
- thread size does not correspond to needle size (thread is too thick)

Solutions:

- replace or polish the damaged parts
- re-adjust looper and/or loop stroke
- re-adjust thread tension, check thread course
- choose the correct thread size

PLEASE OBSERVE: thread course, thread, stitch plate with plunger and cloth retainer, needle and thread tension should always be set and chosen according to the material to be sewn.

● **Inexact needle penetration**

Possible reasons:

- worn out or damaged needle
- wrong pressure or setting of cloth retainer
- wrong setting of stitch plate or needle guide
- damaged or worn out needle glide plate
- wrong needle size (too thin)
- damaged plunger or wrong plunger setting

Solutions:

- replace damaged needle, choose suitable needle size
- check settings and re-set, if necessary
- replace needle glide plate

- **Unintended skip stitching**

Possible reasons:

- wrong looper setting
- wrong setting of loop stroke/needle stroke, therefore insufficient loop formation (small/big)
- chaining finger damaged or not correctly set
- wrong setting of cloth retainer or cloth retainer pressure

Solutions:

- operate machine manually, check the looper motion
- check the settings, re-set, if necessary, replace damaged parts
- change thread feed through thread take-up, if necessary

- **Machine does not start, although the control lamp at the main switch lights**

Possible reasons:

- thread trimmer not in final position, micro switch locks
- control error
- mechanical damage, machine blocks

Solutions:

- switch machine off and on again, check the knives' basic position, check the programming
- eliminate mechanical problem, call service, if necessary

- **The fabric is marked or damaged**

Possible reasons:

- unsuitable feed dog teeth
- plunger shape unsuitable for the fabric to be sewn
- pressure of cloth retainer too high
- wrong setting of feed plates pressure
- damaged sewing tools (lower side of stitch plate)
- unsuitable needle or thread size

Solutions:

- replace feed dog or plunger (variable sewing tools)
- check pressures, sewing tools and their functions, replace or repolish damaged parts
- choose most suitable needles and threads

- **Material feed problems**
(stitch length different from settings)

Possible reasons:

- feed dog setting is not correct, material cannot be caught sufficiently.
- unsuitable feed dog toothing
- different pressures on the left and right hand feed plates
- feed plates lift is blocked
- material accumulation in the stitch plate, mainly over cross seams
- seam or loop are caught by the feed dog
- unintended stitch length modification
- spring-loaded plunger blocks in the cross seam area
- wrong tension of the belts from the bottom feed

Solutions:

- check feed dog setting and stitch length, replace feed dog, if necessary
- set material support pressure correctly
- check if lower side of stitch plate, feed or sewing parts are damaged and replace or repolish them, if necessary
- choose correct stitch plate for thicker materials (see "8 Variable sewing tools", "9 Optional extras")
- **only for machines with spring-loaded plunger:**
check the functions of plunger and limit stop, re-adjust settings, if necessary
adjust the correct belt tension

7 Machine maintenance

7.1 General



CAUTION ! Danger of Injury!

Disconnect the machine from the mains and ensure that it is off by pressing the pedal for switching the sewing drive.

Otherwise there is a **danger of injury** from crushing and needle punctures.

Control:

Check at regular intervals by removing the cover (1) Fig. 18 whether sewing dust, thread remnants etc. have accumulated and remove them.

Fig. 18

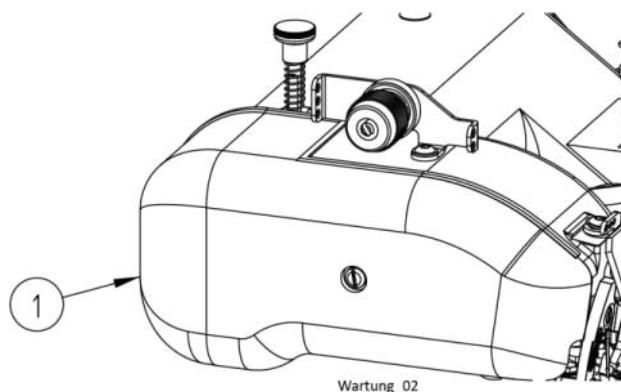

8 Variable sewing tools



CAUTION ! Danger of Injury!

Disconnect the machine from the mains and ensure that it is off by pressing the pedal for switching the sewing drive.

Otherwise there is a **danger of injury** from crushing and needle punctures.

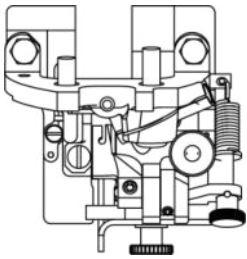
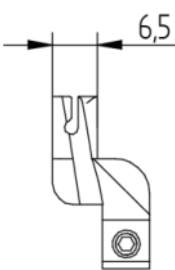
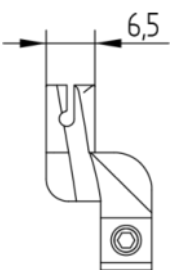
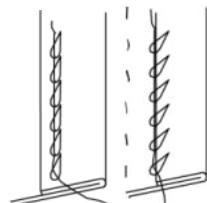
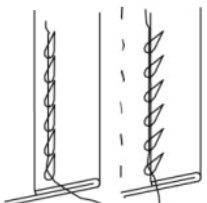
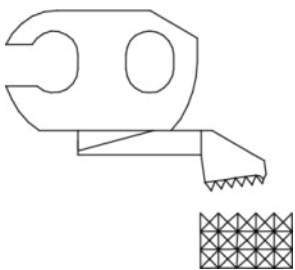
CI. VEB100-3		
<p>Stitch plate</p>	<p style="text-align: center;">Standard 380.0293</p>  <p style="text-align: center;">7,0 mm opening</p>	
<p>Cloth retainer</p>	<p style="text-align: center;">Standard 288.0233</p> 	<p style="text-align: center;">Optional 288.0217</p> 
	<p>Stitch formation</p> 	
<p>Feed dog</p>	<p style="text-align: center;">Standard 182.0151</p> 	

9 Optional extras

The following devices are available as optional extras and can be ordered together with the machine or as separate kits.

9.1 Thread trimmer

898.0496 electromechanical thread trimmer
Prerequisite here is use of the
DAC Classic with connecting cable

9.2 Digital display 392.0637

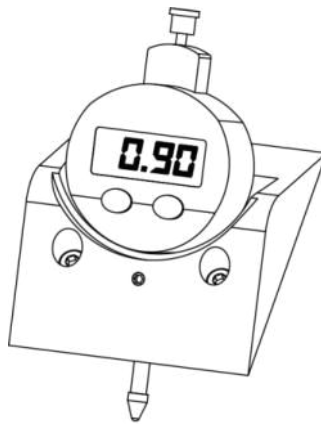

Digitalanzeige_02

9.3 Pneumatic lifting

00000.3607 Pneumatic lifting

Und wir können noch mehr für Sie tun!

Unser Lieferprogramm bietet für jede Branche und jegliche Anforderung genau die richtige Problemlösung.

And we can do a lot more for you!

Our range offers the correct problem solution for every branch and for all requirements.

■ Für die Bekleidungsindustrie:

Ein- und Zweifaden-Hochleistungs-Saummaschinen

Doppelblindstich-Saummaschinen

Zweifaden-Blindstich-Staffiermaschinen

Roll- und Flachpikiermaschinen

Pikier-Automat

und

weitere Spezial-Nähmaschinen

■ *For the clothing industry:*

Single and two thread high performance hemming machines

Bluff edge hemming machines

Two thread blind stitch felling machines

Roll and flat padding machines

Automatic lapel padding machine

and other special sewing machines

■ Für die Schuhverarbeitung:

Einfaden-Überwendlichmaschinen mit und ohne Differentialtransport

■ *For the shoe industry:*

Single-thread overseaming machines with and without differential feed

■ Für Kürschnereien und Pelzkonfektion:

Pelzschnellnäher

■ *For the fur industry:*

High-speed fur sewing machines

■ Für Heimtextilien:

Ein- und Zweifaden-Blindstichmaschinen

■ *For the home textiles industry:*

Single and two thread blind stitch machines

■ Für die Polsterverarbeitung:

Ein- und Zweifaden-Überwendlichmaschinen

Ein- und Zweifaden-Blindstichmaschinen

■ *For the upholstery industry:*

Single and two thread overseaming machines

Single and two thread blind stitch machines

■ Für die Konfektion technischer Textilien:

Ein- und Zweifaden-Überwendlichmaschinen

■ *For the processing of technical textiles:*

Single and two thread overseaming machines

Noch Fragen?

Dann rufen Sie uns an, schreiben Sie uns oder kommen Sie einfach bei uns vorbei.

Sie können jederzeit weitere Informationen über unsere Produkte anfordern oder die Strobel-Nähmaschinen in unserem Ausstellungsraum live erleben. Wir freuen uns auf Sie!

Any further questions?

Then phone, write or simply come and see us. You can have further information about our products at any time, or experience the Strobel machines live in our show room. We're looking forward to meeting you!

STROBEL

Spezialmaschinen GmbH

Postfach 1242
82168 Puchheim
Boschstraße 16
82178 Puchheim
DEUTSCHLAND

www.strobel.biz
Telefon: +49 89 80096-0
Telefax: +49 89 80096-190